

## Univent

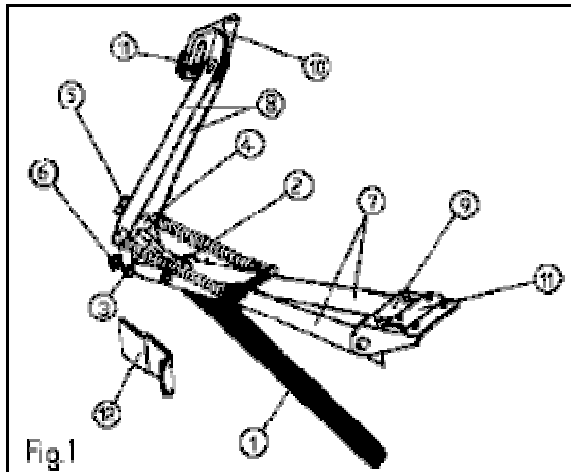

### Components:

See fig.1

1. Cylinder
2. Cylinder housing
3. Piston rod
4. Clutch T
5. Hair pin
6. Stop pin
7. Arm B
8. Arm A
9. Frame bracket
10. Window bracket
11. Clamps
12. Mounting bracket

### Notes:

1. Your automatic vent control is not suitable for use where temperature will exceed 50°C/122°F
2. Ensure that your greenhouse window or cold frame light is able to open and is not obstructed otherwise damage could occur

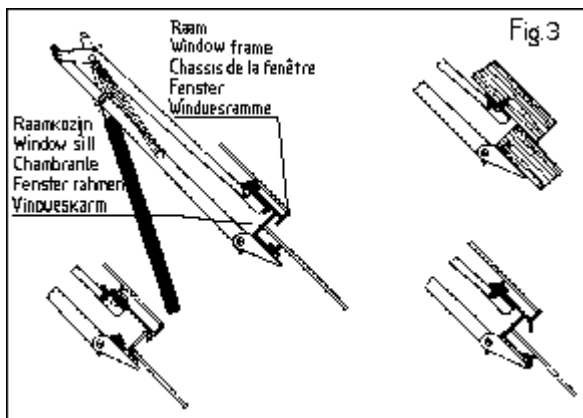

### Technical data:

- A. Maximum window opening approximately 45 cm/18"
- B. Maximum window opening at 30°C/86°F depending on adjustment and load
- C. Suitable for greenhouse vents or cold frame lights weighing up to 7 kg/15 lb

### Maintenance:

Lubricate all movable parts with a light oil after fitting, each spring and as required during the summer. Apply petroleum jelly or grease to the cylinder thread occasionally.

### Guarantee:

A correctly fitted and used UNIVENT is guaranteed for 1 year provided that it has been fitted and maintained in accordance with the instructions.

### Winter-storage:

It is recommended that your UNIVENT - or at least the cylinder - be removed from your greenhouse or cold frame for the winter. Store it in a dry place and do not forget to lubricate particularly the piston rod before remounting in the spring. Check that the piston rod moves smoothly.

### Fitting instructions:

1. Check that your greenhouse window or cold frame light opens freely and is not obstructed

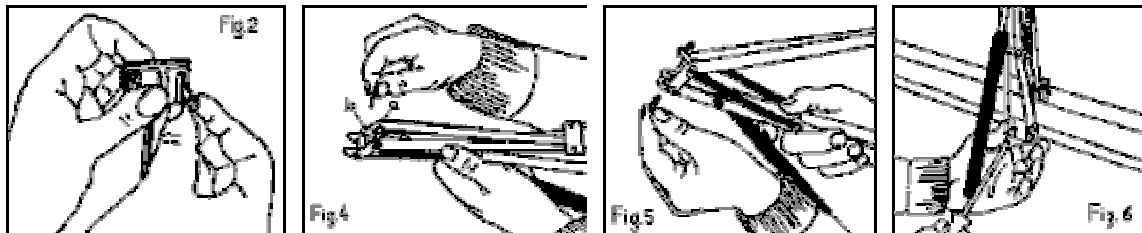

### Greenhouses: Windows in roof and sides:

2. Loosely fit a clamp (11) to the window bracket (10) using two of the screws supplied. See fig. 2. On wooden greenhouses the brackets can be screwed directly on to the woodwork. See fig. 3.
3. Choose the most suitable pair of holes and loosely fit the other clamp to the frame bracket (9). Ensure that the upper edge of the frame bracket is as close to the edge of the window frame as possible. See example in fig. 3.
4. Now measure the distance your window will open.

**A: If the window will open at least 42 cm/16½":** Push the piston rod (3) through the cylinder housing (2) into the clutch T (4). The hole in the piston rod should be placed in line with hole "a" in the clutch T. the hair pin (5) should then be fitted through the hole, see fig. 4.

**B: If the window will open between 30-42 cm/12-16"** Follow the same procedure as described above except remove the plastic cap from the clutch T (4) and use hole "b" and fit the stop pin (6) on to the arm (7). See fig. 5.

**Important:**

**Do not fit the stop pin (6) unless the hair pin (5) is placed in hole b"**

5. Fit the frame bracket to the windowsill, see fig. 6
6. Fit the window bracket to the window frame just above the frame bracket. **The window must be in the closed position.**
7. Open the window sufficiently to allow you to screw the cylinder into the cylinder housing. Screw in the cylinder until the thread has got equal length on both sides of the housing and then release the window.

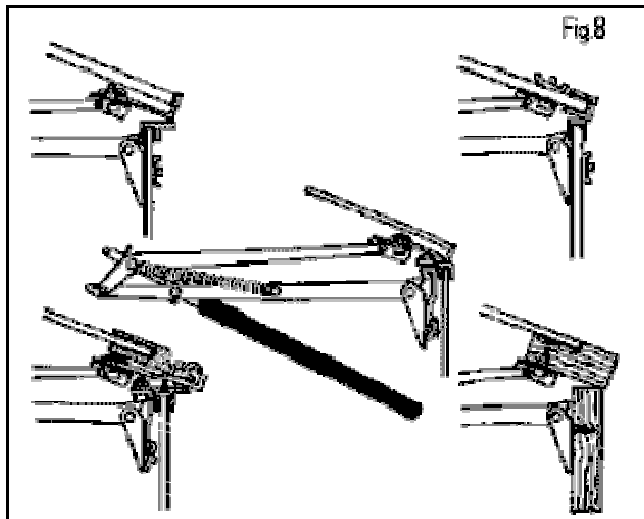
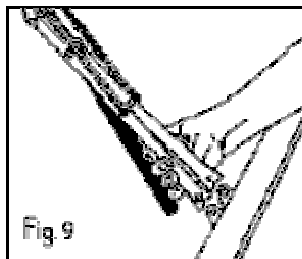
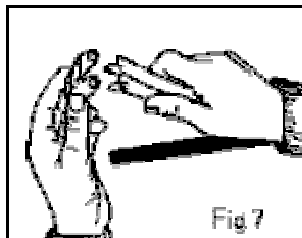

**Cold frames:**

8. Turn the frame bracket (9) 90° as shown in fig. 7.
9. The opener should be fitted in the middle of the front side and light of the cold frame.

**A: Aluminum frame with glass in sides and lights:**

Proceed as described under greenhouses, item 2 and 3. See fig. 8. If neither the frame bracket nor the window bracket can be fitted to the aluminum frames, the enclosed mounting bracket (12) should be fitted. If

none of the brackets supplied can be fitted, you should make your own brackets.

**B: Wooden frames and frames with plastic sheets:**

On wooden frames the brackets can be screwed directly on to the woodwork, see fig. 8. On frames using plastic sheets in sides and lights, holes should be drilled through the sheeting and the clamps are used as nuts for the screws, see fig. 8.

10. Disconnect the frame bracket (9) from the arms (7) and fit it to the frame.
11. Fit the window bracket to the frame of the light.
12. Assemble the arms and the frame bracket as shown in fig. 9 & check that the light can be fully opened and closed.
13. Now dismount the entire opener and proceed as described under greenhouses item 4.
14. Screw the cylinder (1) into the cylinder housing (2) and fit the entire opener again.

**Adjustment:**

It is recommended that the UNIVENT be adjusted only when the temperature in the greenhouse is constant, as it will take some time before it has responded completely to changes in the temperature. If you want the UNIVENT to start opening the window at a different temperature adjustment may be done by turning the cylinder:

**Clockwise to achieve an earlier/higher opening.**

**Counter clockwise to achieve a later/lower opening**

One turn corresponds to app. 0,5°C / 1°F.- Please note that the temperature in the greenhouse may vary considerably, also at the individual windows.