

INSTALLATION AND OPERATION INSTRUCTIONS
FOR AMERICAN COOLAIR'S
**OPEN TOP PVC
EVAP-PAD COOLING SYSTEM**

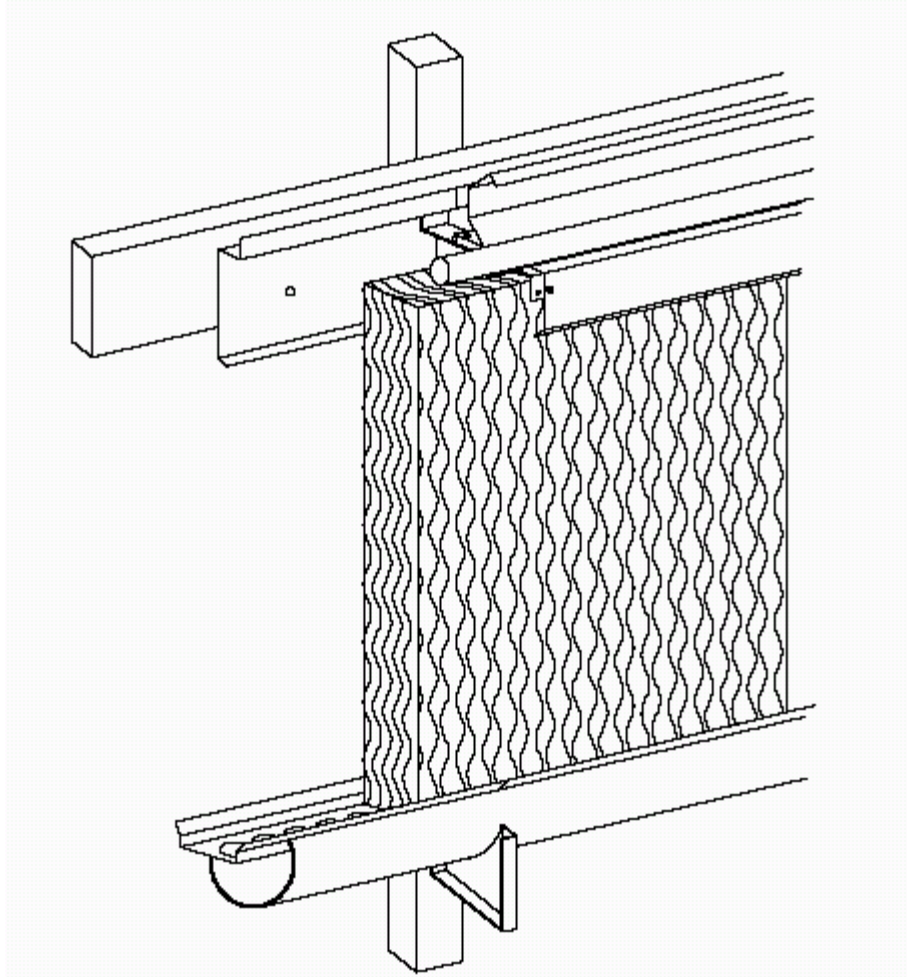

Distributed By:



Hydro-Gardens
P.O. Box 25845
Colorado Springs, CO
80936-5845
888-693-0578
hgi@hydro-gardens.com
www.hydro-gardens.com



TABLE OF CONTENTS

	PAGE
I. CONCEPT OF EVAPORATIVE COOLING	2
II. RECOMMENDED TOOLS	3
III. PARTS LIST	3
IV. PAD LOCATION IN BUILDING	4
V. INSTALLATION PROCEDURES	4
VI. START UP PROCEDURE	13
VII. OPERATION INSTRUCTIONS	14

I. CONCEPT OF EVAPORATIVE COOLING

To offset periods of extreme temperature that affect the in-house environments, and therefore production, Coolair evaporative cooling systems are used with outstanding success. The benefits of evaporative pad cooling are obtained by moving large quantities of air through water-saturated pads. The resulting evaporation of water will lower the air temperature 10 to 25 degrees. This method of cooling can provide dependable relief from heat stresses in periods of hot weather. Suited for all geographic locations, a Coolair Evap-Pad System delivers the greatest economic benefits in areas where higher temperatures during longer periods of time are normal.

II. RECOMMENDED TOOLS

The following is a list of tools required for the installation of your Coolair Evap-Pad System.

Tape Measure	Hack Saw
Chalk Line	Jigsaw or Circular Saw
Level	Tin Snips
Drill with 5/32" Drill Bit	1-1/2" Hole Saw
3/8" and 5/16" Sockets and Drive	2" Hole Saw (for Submersible Systems)
Caulk Gun	2-1/4" Hole Saw (for Centrifugal Systems)

A 1-1/2" PVC Pipe Cutter is recommended, but not required.

III. PARTS LIST

A. Your Coolair Evap-Pad System consists of:

1. A water distribution and return system complete with the correct number of the following parts:
(Number of some parts is dependent upon size of system)

1-1/2" PVC Distribution Pipe	PVC Pipe Cement
1-1/2" PVC Pipe	Distribution Pipe Supports
1-1/2" PVC Ball Valve	Spray Deflector Assemblies
1-1/2" PVC 90° Elbow	Front Covers
8" PVC Trough Pipe	Back Plates
8" PVC Trough End Cap	End Caps
12" PVC Sump Pipe	Drip Pans
12" x 12" x 8" PVC Sump Tee	Trough Hangers
12" PVC Sump End Caps	Joint Covers
Various Fasteners	
Pad Retainers (for 7' and 8' systems only)	

2. A Plumbing Kit that consists of the following PVC accessories:

1-1/2" Couplings	Automatic Float Valve
1-1/2" Ball Valve	1-1/2" In-Line Filter
1-1/2" x 1-1/2" x 3/4" Tee	3/4" Hose Bibb
Threaded Pump Adapters	Weld-On Adhesive (centrifugal pumps only)

3. A Center Mounting Kit (for systems 65' and longer only) with the following PVC accessories:

8" x 8" x 8" Tee	1-1/2" 90° Elbow
8" Trough End Cap	1-1/2" 45° Elbow
1-1/2" x 1-1/2" x 3/4" Tee	1-1/2" Ball Valve

4. Evaporative Cooling Pads

5. Sump Pump

Note: Depending on type of system, not all parts may be used.

B. Parts required for the Evap-Pad System, but that are not supplied by Coolair consist of:

1. Framing Materials
2. Water Supply to Float Valve

IV. PAD LOCATION IN BUILDING

For greenhouse applications, the pads' midpoint should be centered on the crops to be cooled. The pads should be located on one end of the building and the fans on the other end, except in wide greenhouses where the pads should be on one side and the fans on the opposite side.

For poultry or livestock applications, the top of the pads should be at the highest level at which cooling is desired. The pads should be located on one end of the building except in cases where the resulting air velocity exceeds the comfort level for the animals being housed. In these cases, the pads should be on both sides at both ends of the house, with the fans on both sides in the middle. See Figure 1.

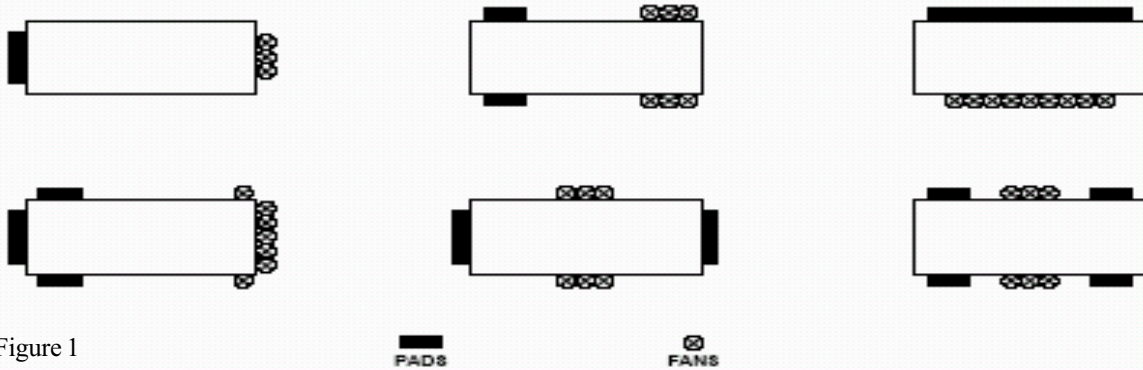

Figure 1
Many other designs are acceptable. Contact your Coolair representative for recommendations.

V. INSTALLATION PROCEDURES

The desired opening should be the ordered pad height plus 1". For example, if you ordered a 45' system which is 5' tall, then your opening would be 45' x 61". See Figure 2. This opening should have 4 x 4 vertical stringers on 5 foot centers, and a minimum 2 x 6 horizontal upper stringer, all made of water-resistant wood. When fastened to a metal building or greenhouse, the opening should be framed with angle or Z support of sufficient strength to support a maximum of 45 pounds per linear foot of pad for 6" pad systems. There should be a minimum of 6" clearance from the top of the upper stringer to any obstruction that would hinder routine maintenance, such as clearing clogged holes in the pipe. There must also be a minimum of 6" below the opening for proper installation of the collection trough. Also, the sump must sit a minimum of 20" below the opening. For systems 5' to 60' long, the sump will be located at the end of the system. For systems 65' to 110' long, the sump will be located at the center of the system.

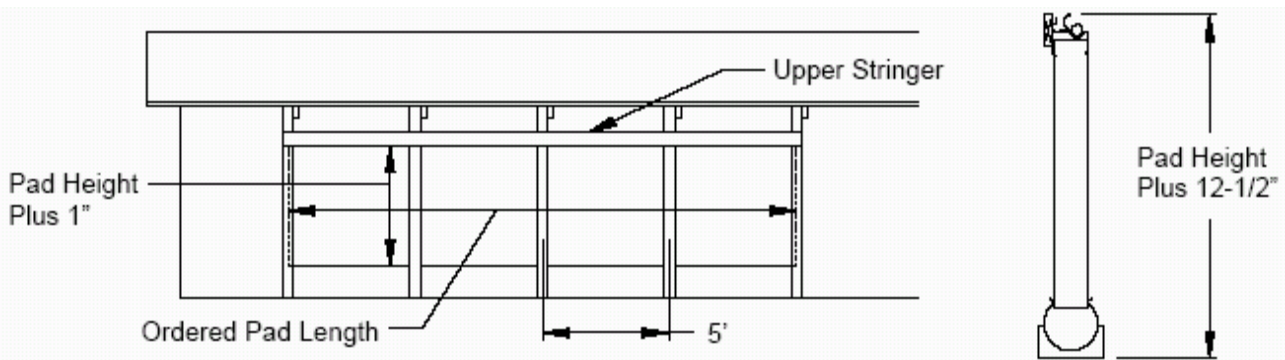

Figure 2

A. INSTALLATION OF VERTICAL STRINGERS

To properly support the Evap-Pad System, vertical 4 x 4 stringers should be installed in the opening. These stringers should be placed at both ends of the system, and centered every 5 feet along the opening. Stringers should be securely fastened (preferably to the roof trusses) at the top and firmly seated in the ground (or otherwise supported) at the bottom.

B. INSTALLATION OF UPPER STRINGER AND TROUGH HANGERS

Locate the Evap-Pad System vertically as determined by the specific use of the system. The bottom of the upper stringer should be located flush with the top of the opening. Once the stringer location has been determined, mark this position on one of the end vertical stringers. Then, locate a corresponding level point on the opposite end stringer. Use the chalk line to mark all remaining stringers, and install the upper stringer. Next, measure down from the bottom of the upper stringer the system pad height plus 1", and mark this point on both end stringers. These points should be at the same height as the bottom of the opening. Again, mark each stringer with the chalk line. Place the trough hanger on each stringer so that the top of the hanger is on the chalk line. Mark the locations of the holes in the hanger and drill pilot holes. Install a trough hanger on each vertical stringer using the rubber grommeted lag bolts. See Figure 3.

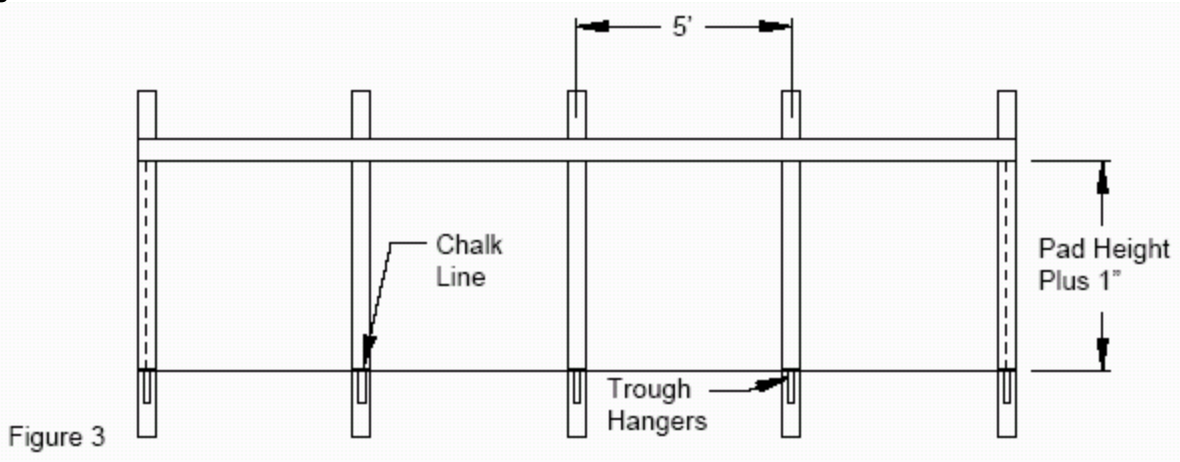

C. INSTALLATION OF THE MIDDLE STRINGER

When 7 or 8 foot pads are used, it will be necessary to install a 1 x 4 middle stringer. This stringer should parallel the upper stringer. Figure 4 shows the position of the top of this stringer with respect to the bottom of the upper stringer.

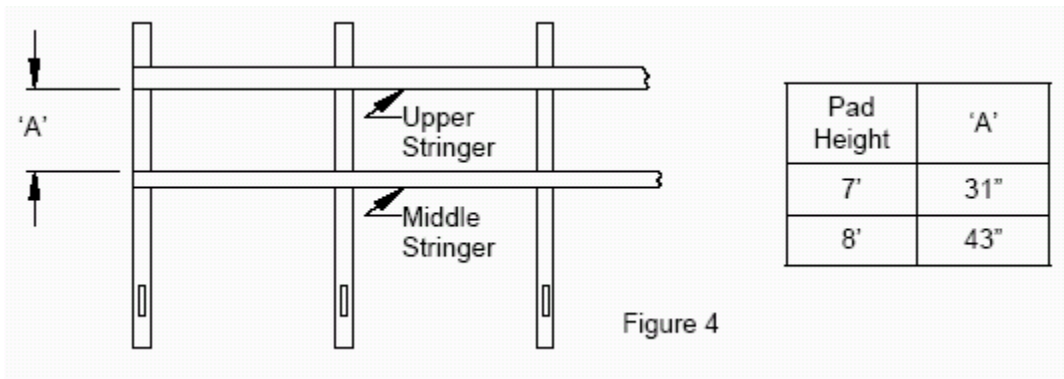

D. TROUGH CONSTRUCTION

For systems 5' to 60' long — The sump will be located at the end of the system. Using the PVC cement, glue the 8" pipe sections together. Apply the cement about 1-3 inches wide around the standard end of each length of pipe, and slip it about 3-4 inches into the "bell" end of the next pipe. Let all sections of the pipe dry thoroughly. Next, measure a length of this pipe equal to the system length plus about 18" - 30". This will be the length of the trough. (Actual trough length will depend on the location of the sump.) Before cutting the pipe to length, check the location of the trough joints against the position of the trough hangers to make sure they do not coincide. If they do, change the location of the cut marks. Using a saw, cut off the excess pipe and discard. Now glue the 8" pipe cap onto the end of the pipe opposite the sump end. Place the trough on the trough hangers so that the open end faces the proposed sump location. The end cap on the opposite end should clear the last hanger.

For systems 65' to 110' long — The sump will be located in the center of the system, assuring an adequate water supply throughout the entire system. Equal lengths of 8" pipe will be glued on each side of the 8" tee. Using the PVC cement, glue the 8" pipe sections together and to the 8" tee. Apply the cement about 1-3 inches wide around the standard end of each length of pipe, and slip it about 3-4 inches into the "bell" end of the next pipe. Let all sections of the pipe dry thoroughly. Next, measure a length of this pipe equal to the system length plus about 18". This will be the length of the trough. Before cutting the pipe to length, check the location of the trough joints and the tee against the position of the trough hangers to make sure they do not coincide. If they do, change the location of the cut marks. Using a saw, cut off the excess pipe. Save it to connect the 8" tee to the sump. Now glue the 8" pipe caps onto the ends of the 8" pipes. Place the trough on the trough hangers so that the open end of the tee faces the proposed center sump location. The end caps on the 8" pipes should clear the end trough hangers.

Next, two slots will need to be cut in the pipe. Mark a chalk line that is the exact length of the system along the length of the pipe. This line should be aligned with the wall opening. Using a jig saw or circular saw, cut along this line, making sure not to cut beyond either end of the mark. Locate the position of the next slot by measuring circumferentially along the outside of the pipe. The second slot will be of the same length, parallel to the first and located 7-5/8" away from the first. Measure and mark the second slot with the chalk line and cut the second slot like the first. When cutting the slots, it may be easiest to rotate the pipe so that the slot line is on the top. Finish making the trough opening by marking a line connecting the ends of the slots and cut with a saw. Remove the cut out piece of PVC and deburr the entire pipe. Make sure to remove all PVC chips from the trough when finished. Figure 5 shows the trough.

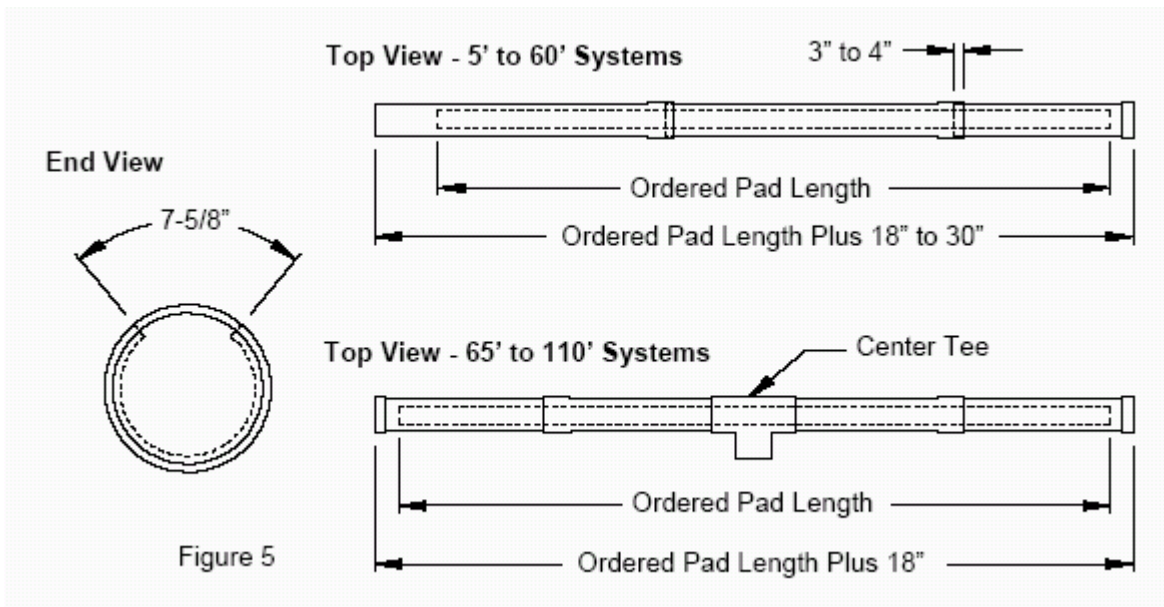

E. SUMP CONSTRUCTION

The sump consists of the 12" PVC parts. Start by cutting two pieces of the 12" pipe. The first piece should be about 8" long. This piece will be used above the tee. The second piece will be placed below the tee, and will determine how far below the bottom of the system the sump will sit. This piece may be cut at any length over 12" to suit your needs for sump placement, although it is recommended that this piece be greater than 24". When the sump is properly placed, the 8" tee section should be level and in line with the trough. Deburr both cut pieces of the pipe. Using the PVC cement, glue both pieces to the tee, and one of the 12" PVC caps to the bottom piece. Do not glue the other cap to the upper piece, as it will be necessary to remove this cap for inspection and maintenance of the sump.

Next, the float valve must be installed. To do this, first assemble the valve per the manufacturer's instructions to the "Normal Position," but do not insert the thumb screws yet. Make a mark on the tee 3-3/4" up from the centerline of the 8" section. Then, make another mark at the same height 5" away (circumferentially) from the first, and drill a 1-1/2" hole centered on each mark. It is recommended that you now attach your 3/4" water supply hose to the float valve. Mount the float valve by sliding its supports through the holes from the inside of the sump out. Position the valve such that the supports are in the center of the 1-1/2" holes. This will allow for height adjustment at system start-up. Now, insert and tighten the thumb screws.

To insure that the water level in the trough never reaches the bottom of the pads, it will be necessary to drill an overflow hole in the tee. Using the 1-1/2" bit, mark and drill a hole in the tee centered at 2-1/8" up from the centerline of the 8" section of the tee. Figure 6 shows the sump hole locations. If you are using a bit that is not 1-1/2" in diameter, make sure the bottom of the overflow hole is exactly 1-3/8" up from the centerline of the 8" section of the tee. After all holes have been drilled, deburr them, and make sure to remove all PVC chips from the inside of the sump.

Now, place the sump in position so that its 8" tee section is exactly aligned with the trough (for end sump systems) or with the 8" x 8" x 8" tee (for center sump systems). For a center sump system, use the piece of 8" pipe cut from the trough to connect the sump tee to the trough tee. Apply PVC cement to the end of the trough (and the connector piece for a center sump), and slide the pieces together. Make sure the opening in the trough is level and aligned with the wall opening when the cement dries.

After the sump and trough have been assembled, you will need to create an air-tight seal between the stringers and the trough. This may be done by installing a 1 X 2 on top of the trough hangers between the trough and the stringers. Once this is done, caulk the seam between the 1 X 2 and the trough. See Figure 7.

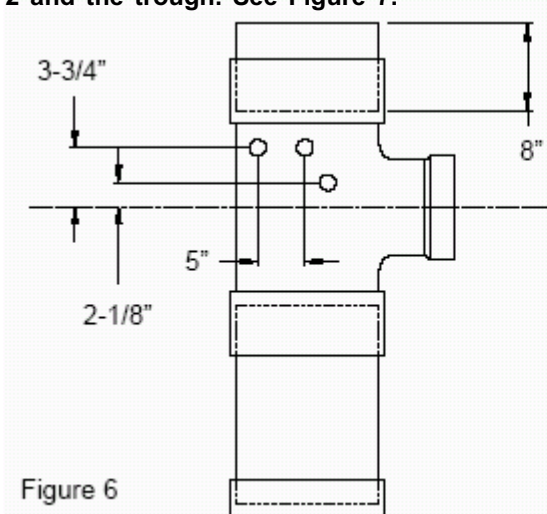

Figure 6

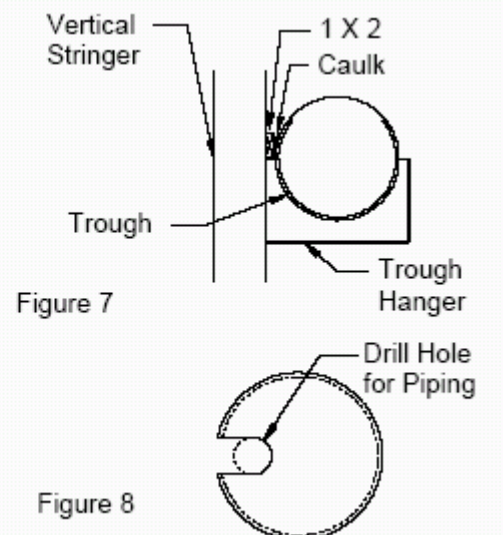

Figure 7

Figure 8

To allow for piping into and out of the sump, a slot must be made in the remaining 12" PVC cap. For centrifugal systems, drill a 2" diameter hole in the cap near the edge. For submersible systems, drill a hole just large enough for the supply hose. Then with a jigsaw or hack saw, cut from the edges of this hole radially out of the cap. See Figure 8.

F. INSTALLATION OF THE BACK PLATES AND PIPE SUPPORTS

For ease of installation, mark a point 1-1/2" up from the bottom of the upper stringer. Do this at both ends of the system. Next, mark a chalk line through the two points. This indicates the location of the back plate mounting holes. Sight through the 6 pre-punched mounting holes in each back plate and line up the chalk line through them. This puts the back plate and pipe support at the correct mounting height. Secure in place using the rubber grommeted lag bolts. See Figure 9. Caulk the joints between all back plates to help prevent water leaking to the stringer.

The pipe supports can now be installed onto the back plates. Use the pipe supports shown in Figure 9. All holes are pre-punched. The two pipe supports on the very ends of the system mount so that they are flush with the end of the first and last back plates. The remainder of the pipe supports are to be installed so that they span each joint where the back plates butt up to each other. Secure in place using the rubber grommeted lag bolts. Caulk any unused holes in the back plates to help prevent water leaking to the stringer.

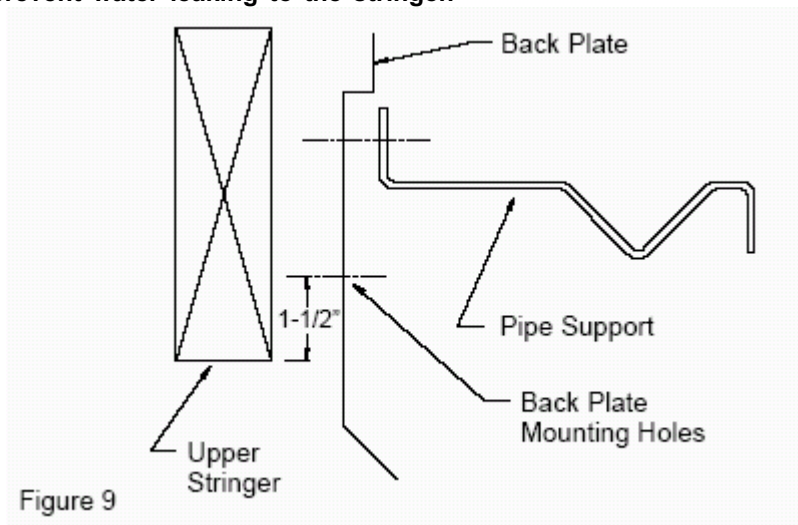

G. INSTALLATION OF THE SPRAY DEFLECTOR ASSEMBLIES AND JOINT COVERS

Next, the spray deflector assemblies are to be mounted to the top of the pipe supports. Each end of a spray deflector assembly overlaps one half of the pipe support that it attaches to, except at the ends of the system, where the entire pipe support is overlapped. Use the 1/4" bolts and nuts provided, but do not tighten the hardware yet. At each joint where the spray deflector assemblies butt up to one another, a joint cover will be installed. With the spray deflector hardware loose, slightly lift up two adjacent spray deflector assemblies and slip a joint cover under them, nesting the joint cover on the inside of the two spray deflector assemblies. See Figure 10. Repeat for all of the joints and then tighten the hardware securely.

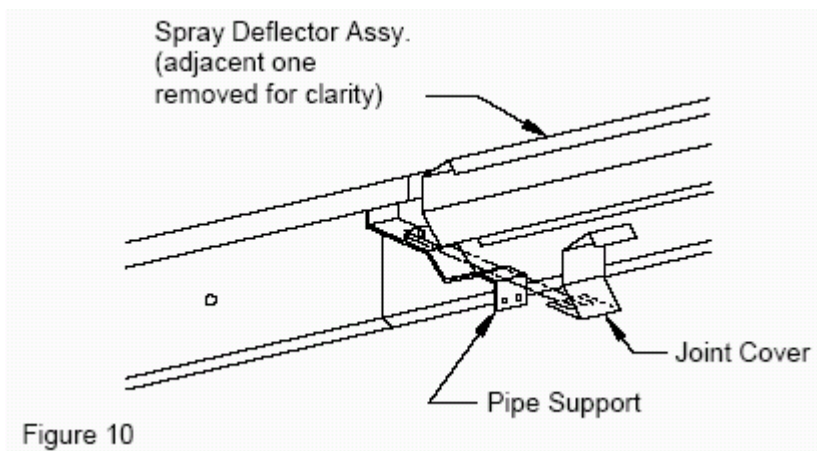

H. INSTALLATION OF THE DISTRIBUTION PIPE

To install the pipe, place a 10 foot section on top of the pipe support with the metered holes pointing at the 11 o'clock position when viewed from the end. This position is necessary to provide proper water distribution. Figure 11 shows the proper positioning of the distribution pipe. Continue joining pipe sections together, placing the standard end of one pipe into the "bell" end of the next. The connections do not need to be cemented, but should be pushed together tightly. For center pump systems, a 1-1/2" x 1-1/2" x 1-1/2" tee needs to be put into the middle of the system. It will need to angle up at 45° to clear the front cover. See Figure 14 or 16 for piping details.

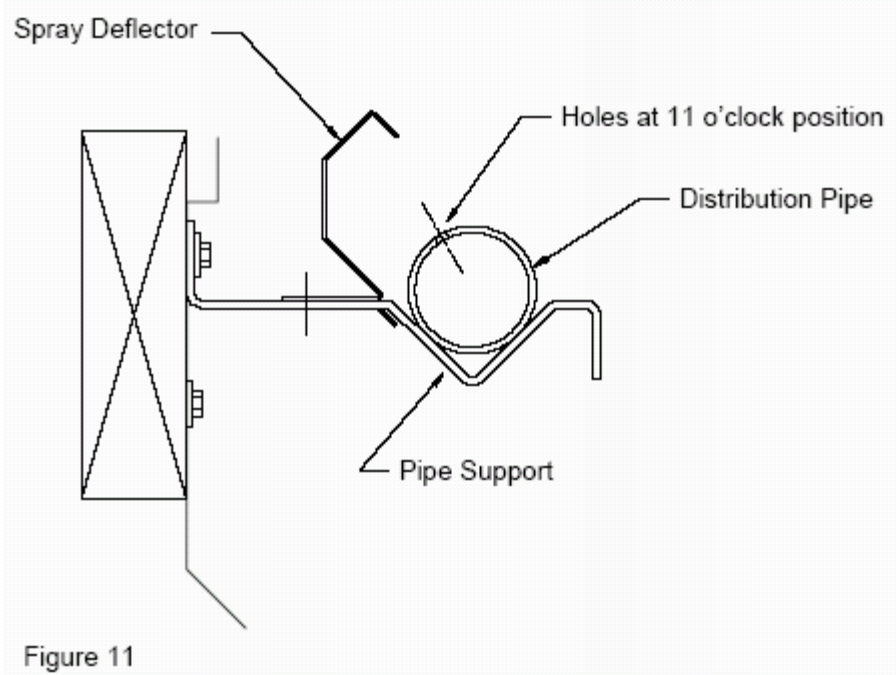

I. INSTALLATION OF THE DRIP PANS AND EVAPORATIVE PADS

The evaporative cooling pads can now be placed onto the assembled trough. First, place the 5' drip pan sections the length of the trough. The drip pans will act as a seat for the pads.

If the system is 6 feet high or shorter, just place the pads onto the drip pans, sliding the pads up against one another.

If the system is 7 or 8 feet tall, a pad retainer is used at each intersection of four pads to prevent them from separating. Place a bottom pad (4 ft. tall) into position on the drip pan. Next, set the top pad on top of the bottom pad. Slip a pad retainer onto the middle stringer and slide it over the joint of the two pads. Now install two more pads, sliding them into the rings of the already installed pad retainer. Repeat this procedure for the entire length of the system. See Figure 12.

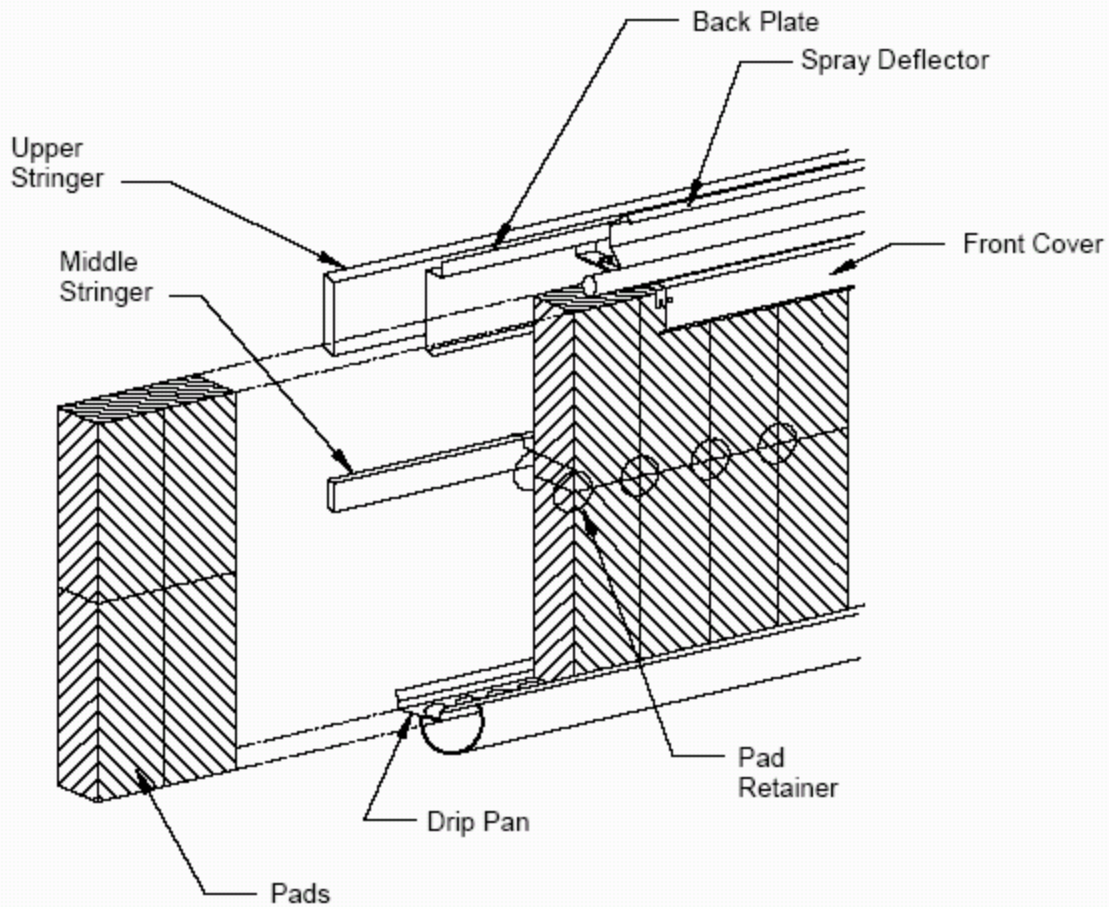

Figure 12

J. INSTALLATION OF THE FRONT COVERS

After the evaporative pads have been set in place, the front covers need to be installed. Each end of the front cover overlaps one half of the pipe support that it attaches to. Use the stainless steel self-tapping screws provided to mount the front covers to the pipe supports. See Figure 12.

K. INSTALLATION OF THE END CAPS

Next, the end caps are to be installed. Two different sets of end caps are supplied. Use the pair that has the pre-punched 2-5/16" diameter holes farthest away from the mounting flange. They mount flush with the end of both the back plates and the spray deflectors; one end cap at each end of the system. Put the distribution pipe through the end caps and secure them to the upper stringer using rubber grommets and lag bolts. The end caps may be trimmed if desired. Caulk the opening in the end caps to prevent water from leaking out the end.

L. INSTALLING THE PUMP AND PIPING

Pump:

Operation and maintenance instructions are included with each pump. For submersible pumps, position the pump at the bottom of the sump so that the discharge pipe is near the edge of the sump. If a centrifugal pump is used, an additional 2-1/4" hole will need to be drilled in the sump to provide for an intake pipe for the pump. This hole should be located near the bottom of the section of 12" PVC pipe below the tee, and should be aligned with the intake opening of the pump. Once the hole is drilled, place a 1-1/2" PVC coupling (found in the plumbing kit) halfway through the hole. Using the Weld-On Adhesive, securely seal the coupling to the sump. See Figure 15 or 16.

Piping:

Use the pipe configuration recommended in Figure 13 or 14 for submersible pump systems or Figure 15 or 16 for centrifugal pump systems, to ensure an adequate supply of water for the system. Glue all PVC fittings in the water distribution system from the pump to the In-Line Filter. Be sure to note the direction of water flow through the filter before gluing the system together. Also, glue the end 90° elbow(s) and the end ball valve(s). DO NOT glue the distribution pipes, as they may need to be removed for cleaning and maintenance. Once all of the piping is in place, glue the filter end cap in place.

Once all piping (including the water supply hose connection) has been completed, place the remaining PVC cap on the sump, and cover any remaining openings in the cap to prevent the entry of debris or animals into the sump.

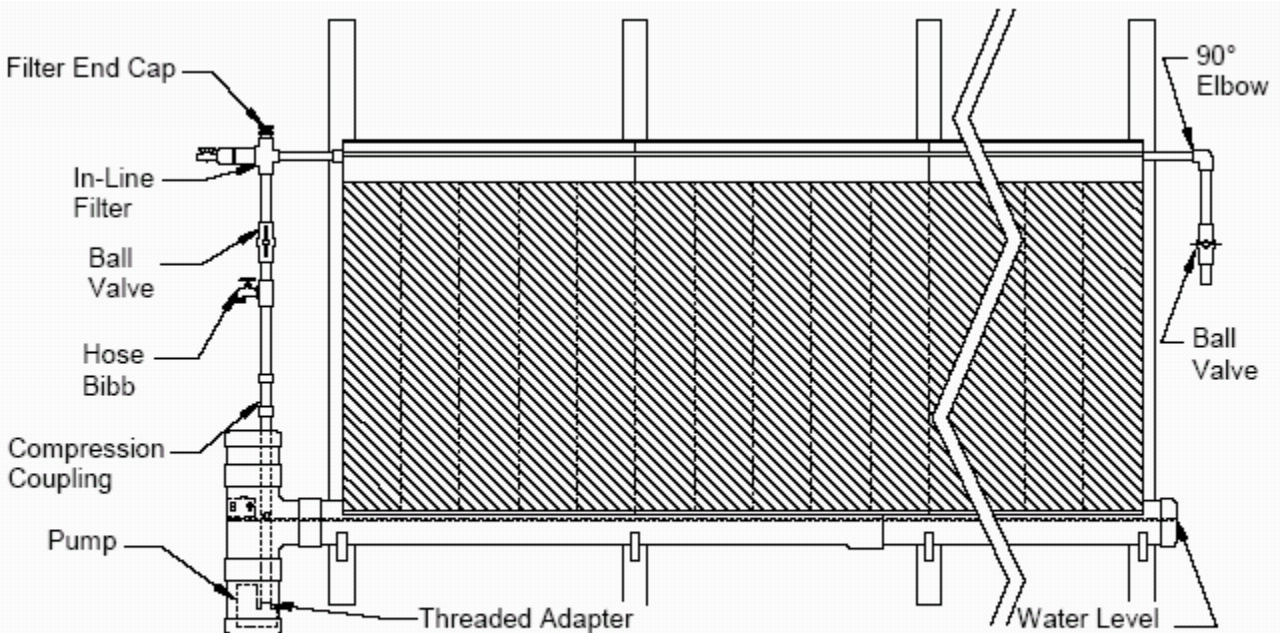

Figure 13 - 5' to 60' Submersible Pump System

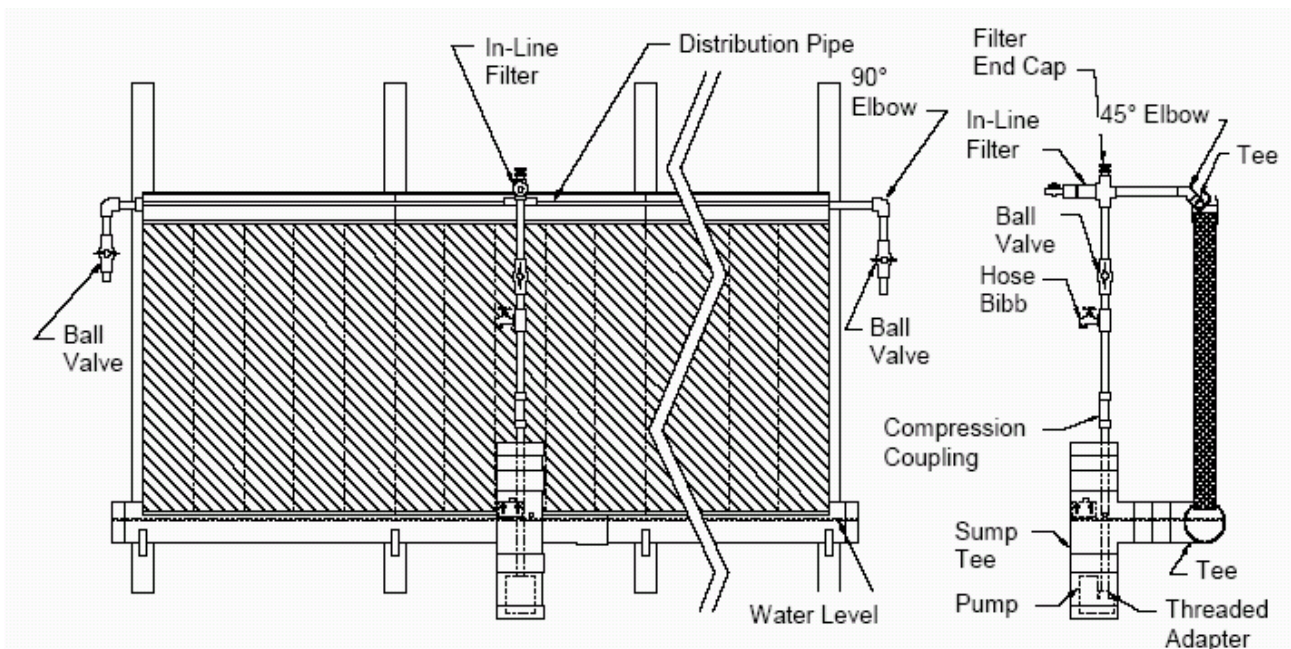

Figure 14 - 65' to 70' Submersible Pump System

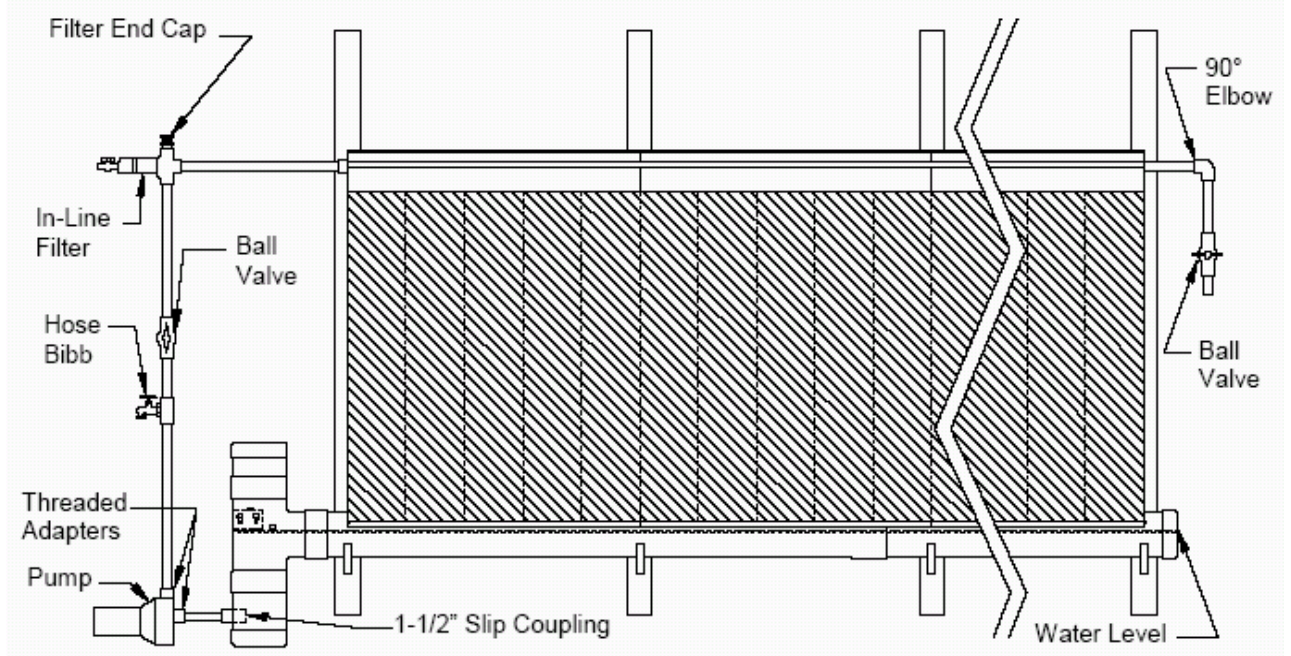

Figure 15 - 40' to 60' Centrifugal Pump System

VII. OPERATING INSTRUCTIONS

1. The pads are very durable and will last 5 or 6 years if properly maintained. When the water is circulated and evaporated, the mineral content of the remaining water gets higher. To keep the mineral content within workable levels, 5% to 10% of the circulated water must be bled off through the hose bibb. When mineral deposits are observed on the pad, increase the amount of bleed off.
2. The pH of the recirculated water must be maintained between 6 and 9. A pH of 7 is neutral. A pH above 9 or below 6 will drastically reduce the life of the pad.
3. Algae growth and water bacteria in the pads must be controlled. The pads are treated with a fungus resistant additive, but this does not completely prevent algae growth. Treat the water with any of the chlorine algaecides (Calcium Hypochlorinates) used for swimming pools, such as HTH or Pace. Tablet forms of these algaecides are the most economical and best to use in the sump for slow release. Maintain the sump water for recirculation at 1 ppm (part per million) chlorine. If a chlorine smell is present, too much has been added. If any algae grows, tablets need to be added. Water pH and chlorine levels should be checked weekly. Kits for testing pH and chlorine may be purchased at any swimming pool supply store. The life of your pad depends on its proper maintenance. Do not use copper sulfate in the system as it will corrode the pump and other metal parts of the system.
4. Clean the filter at least once a week, more often if foreign materials are present in the water system.
5. Flush pipe distribution system at least once a month. This is done by opening both ball valves while the pump is running and allowing water to flow through and out of the system.
6. Regulate your ventilation system so that the pad system is turned off while all the fans are still running. This will pull air through the pads after the water is turned off, allowing them to dry properly and killing any algae spores. Do not keep the pads wet around the clock as this will make the pads soft.
7. When the evaporative pad system is operating, check the pads for dry spots. When dry spots are observed, remove the pipe cover and check the holes in the pipe. Clean any stopped up holes with a wire until adequate water flows from each hole.
8. DO NOT FLOW EXCESSIVE WATER ON THE PAD. The pads are more efficient if they have just enough water to keep them wet, but not a stream of water cascading down the pad.
9. Drain and clean the sump as necessary to remove any dirt or trash that it may have accumulated.
10. At the end of the evaporative cooling season, drain the pump, sump and pipe system to avoid freezing damage in cold weather. If the pump cannot be completely drained, put anti-freeze in it.