

## GUTTER CONNECTED GOTHIC-ROOF HEAVY DUTY GREENHOUSE FRAMES

When you purchase your greenhouse, you should closely consider the following points about gutter connected greenhouses. Since **Hydro-Gardens** has owned and operated greenhouses, and our staff has visited many complexes installed by other manufacturers, we can recommend with authority the best and **easiest to install** greenhouse available today.

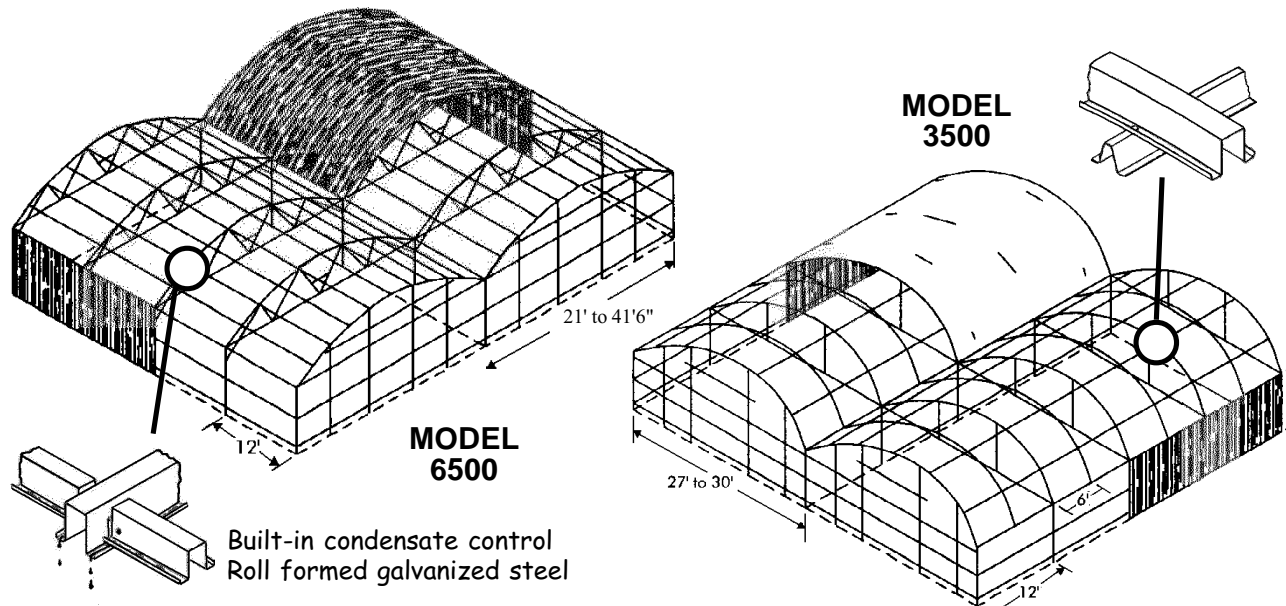

### INSTALLATION

The 30' wide bay is **50% faster** to erect than the 18' wide, and **30% faster** than a 22' wide "bolt together" style greenhouse!

### STRENGTH

Our gutter connected structures are engineered to have the **highest "live" and "dead" (wind and snow) load ratings** in the industry. This is only important when that "freak" storm hits your area. Unlike other greenhouses offered by the industry, **the structure IS the plant support system.**

### EFFICIENCY

Fewer metal gutters exposed to the outside reduces the ongoing heating costs and initial heater size!!

### PRODUCTIVITY

Fewer gutters and 12' truss spacing **reduce shadowing** which increases plant growth and production. **Fewer column posts to work around** increases the efficiency of your work force!! And also reduces concrete cost.

### EXPERIENCE

We, at **HYDRO-GARDENS**, have been growers also!! If we felt there was a better greenhouse structure available, **we would be offering it for sale!!**

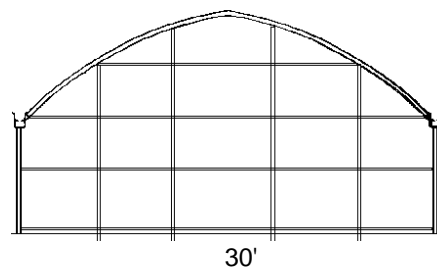

**GALVANIZED STEEL FRAMEWORK**

- \* All models are designed to be covered with rigid or polyethylene sheet plastic.
- \* A nested galvanized steel gutter system over 8" wide and bolted to the gutter saddle.
- \* Optional end and side wall framing as well as other accessories.

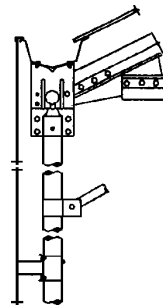

- \* Extra large 3" columns made of galvanized high yield strength steel.
- \* Future additions to these greenhouses may be made in any direction.
- \* Simplified construction with fewer nuts and bolts for **quicker installation.**

We will be happy to "computer design" a **single building or a multiple acre greenhouse complex.** Either the "frame only" or completely designed for your heating, cooling and growing requirements. All systems come complete with comprehensive and detailed documentation.

**CONTACT US FOR A QUOTE**

800-634-6362

## GROUND to GROUND HEAVY DUTY GREENHOUSES

These Extra Heavy Duty Frame Greenhouses are designed for moderate and cold climates that experience high winds and heavy snows. This inexpensive structure is designed to be used as an isolated seedling unit, a starter unit for those just entering the vegetable growing business, a research unit for variety and/or new crop studies, etc.

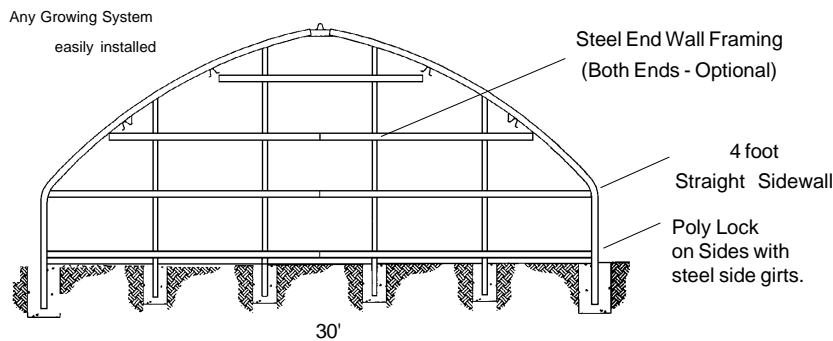
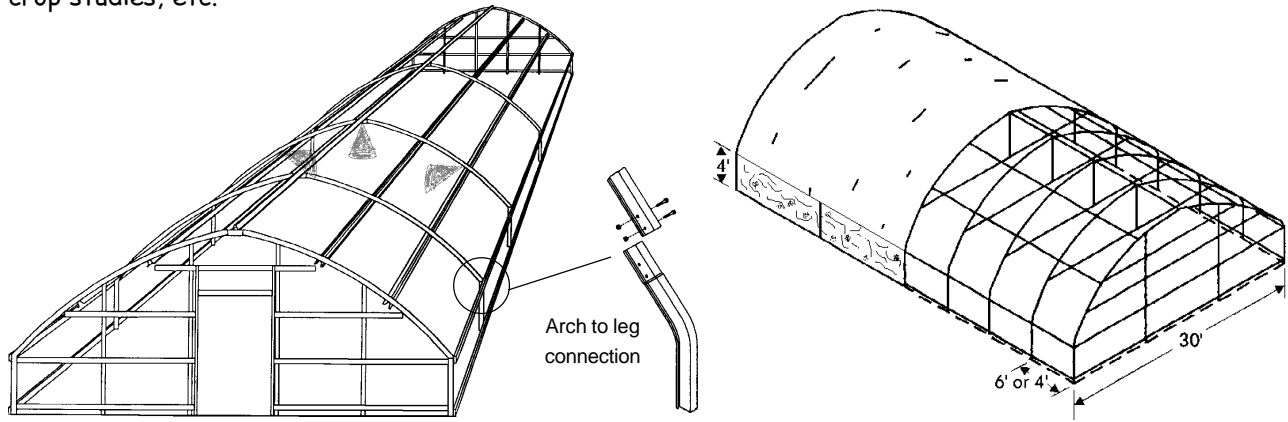

### CUSTOM DESIGNED

When **Hydro-Gardens'** offers a quote on one of our models, we take into consideration the type of climate in which the greenhouse will be located: hot, warm, or cold; arid or humid; windy and snowy. These very important considerations determine to a great extent, the final cost of the greenhouse.

### INCLUDED

**Hydro-Gardens** includes: Flashing for the gable ends; curved poly lock for the gable ends; steel framing for the gable ends when ordered; and gable end heavy crop bracing. These items are seldom, if ever, included by other manufacturers. Consider that it takes nearly **three times** as much wood to fabricate a structurally sound gable end as it does to make it with steel.

### SIDEWALLS

**More head room** than most ground to ground structures. Our greenhouse can be ordered with 48" sidewall height. Sidewall height is a function of the crops to be grown. Bedding plants on 30" benches do well in the 6" sidewall; lettuce on benches, tomatoes and cucumbers with a 48" sidewall.

### PRICES OF OTHER SIZES

48' = \$10,960; 76' = \$12,362; 96' = \$14,264; 120' = \$15,313; 148' = \$17,540.

### GREENHOUSE SAMPLE PRICING:

<b>GREENHOUSE FRAME</b>	
30' x 132' frame with 48" sidewall: .....	\$ 5,892.00
Gable end framing, front and rear: .....	\$ 470.00
<b>COVERING</b>	
Air inflated double poly cover with 6 mil SunSaver inner layer and 6 mil regular outer layer, corr. polycarbonate gable ends, flashing and accessories: .....	\$ 2,890.00
<b>COOLING/ENVIRONMENTAL CONTROL</b>	
Two 48" x 1 HP exhaust fans, evap. cooling, Tstat23 control and poly-vent end wall vent: .....	\$ 3,530.00
<b>HEATING</b>	
One 250,000 Btu heater with four 12" horiz. air flow fans, one 16" dehumidification fan, and one 16" fan control timer: .....	\$ 2,820.00
<b>CROP SUPPORT</b>	
Heavy duty plant support system with #9 galv. wire, horiz. steel crosses, end bracing, and turnbuckles: .....	\$ 788.00
<b>TOTAL</b> .....	<b>\$ 16,390.00</b>

## ***GUTTER CONNECTED PEAK-ROOF HEAVY DUTY GREENHOUSE FRAMES***

Since each greenhouse application defines a unique structure type, we at HYDRO-GARDENS offer a line of custom designed greenhouses including the PEAK-ROOF gutter connected structures. These versatile styles are designed for rigid coverings such as; fiberglass, polycarbonates, and acrylic.

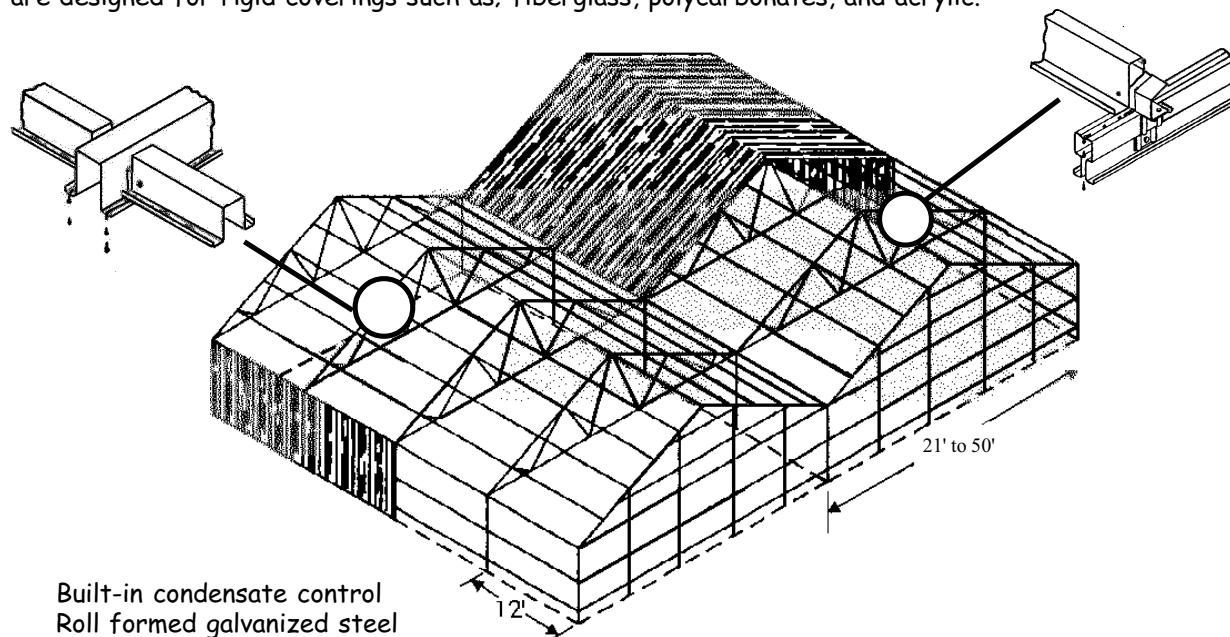

Built-in condensate control  
Roll formed galvanized steel

### **ECONOMICAL**

Like the Arch Roof gutter connect structures, the PEAK ROOF units are configured on 30' wide bays. We have found that this 30' width gives the best and most economical utilization of space for row crops such as tomatoes and cucumbers. Should, however, a greenhouse special design application dictate another bay size, we have several widths available, all of which can be added to existing bays.

### **APPROPRIATE TECHNOLOGY**

PEAK ROOF structures allow for the utilization of roof vent technology to control humidity and provide cooling for special applications. No greenhouse is a "standard greenhouse". For this reason we will consider existing technology in the design of your greenhouse, and present what we feel is the most cost-effective system.

### **TOTAL SYSTEMS**

HYDRO-GARDENS is a total greenhouse company with the ability to design structures with innovative yet practical engineering solutions. We can supply the complete structure, all of the necessary environmental equipment, growing system, growing media supplies, and technical assistance. We know what you need to make a profit with your structure, whether it be in tomatoes, cucumbers, lettuce, herbs and spices, or flowers.

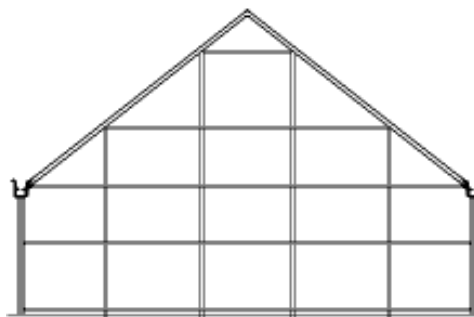

**GALVANIZED STEEL  
FRAMEWORK**

\* All models are designed to be covered with fiberglass, polycarbonate, or acrylic.

\* A nested galvanized steel gutter system over 8" wide.

\* Optional end and side wall framing as well as other accessories.

#### **Roof Vents**

Roof vents decrease electrical cooling costs and improve crop environment. Roof vents are an important tool for fine-tune control of your environment. If roof vents are a justifiable capital expense for your location and crop we will engineer the proper type and size required.

#### **Special Engineering**

If your greenhouse requires unique cooling solutions, we can design specialized systems such as our center cooling chamber and misting network. Packing warehouses and storage facilities can be economically integrated into the greenhouse structure.

## VENTED NATURE-COOL SAWTOOTH ROOF GREENHOUSES

Hydro-Gardens vented sawtooth type greenhouses for natural convection cooling and humidity control. This type of unit is suitable for special locations. They work in areas that have light snowfall, but have high humidity and a slight prevailing breeze. Cooling is accomplished by natural convection, and electrical energy savings for cooling in a greenhouse of this type can be as much as 70% if no vents are needed. These structures are not recommended for locations with a growing temperature that exceeds 90°.

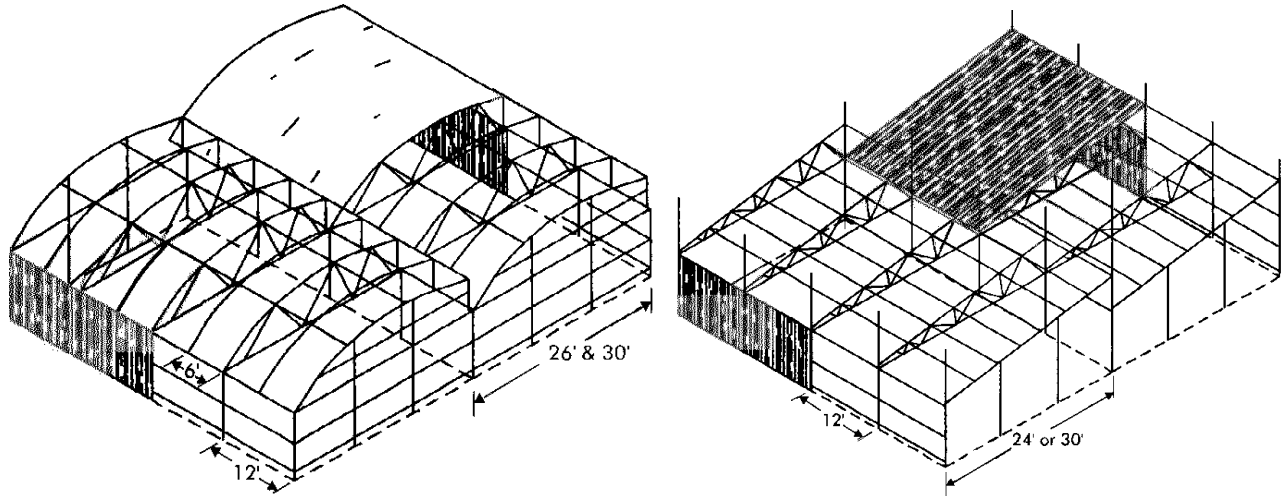

### STRENGTH

Made with roll formed trusses of high strength steel and 3" square galvanized steel column posts, these sawtooth structures can be designed with the highest "live" (wind) load ratings in the industry. This is important when that "freak" storm hits your area. Standard is 10# load.

### PRODUCTIVITY

Fewer gutters and 12' truss spacing reduces shadowing which increases plant growth and production. Fewer column posts to work around increases the efficiency of your work force!!

### NOTE:

Due to the design of natural vented houses, they require at least **TWO (2)** bays for proper cooling. A single house will not vent properly as a stand alone unit!

### Curved Roof Models

These sawtooth units are available in 24', 26' and 30' widths, and were specially designed to be covered with polyethylene sheet.

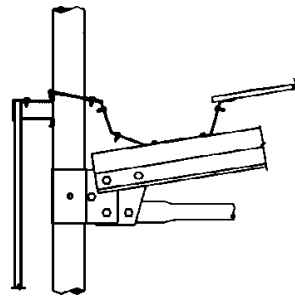

**GALVANIZED STEEL  
FRAMEWORK**

- \* Models are designed to be covered with fiberglass; polycarbonate, or polyethylene sheet plastic.
- \* A nested galvanized steel gutter system over 8" wide.
- \* Optional end and side wall framing as well as other accessories.
- \* Standard clearance is 10' under the gutter with a 4' rise.

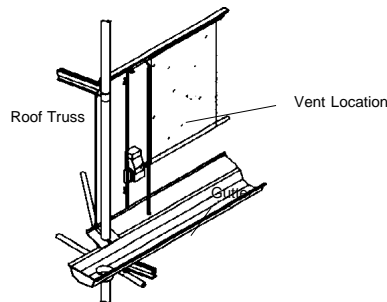

**Typical VENT SECTION**

- \* Each line of roof vents is constructed of a continuous run of rack and pinion, air inflated Poly-Vent, or roll up curtain wall material.
- \* Sidewall vents are available in rack and pinion, air inflated Poly-Vent, or roll up curtain walls.
- \* Simplified construction with fewer nuts and bolts for quicker installation.

We will be happy to design a multiple acre greenhouse complex. Either the "frame only" or completely designed for your cooling and growing requirements. All systems sold have comprehensive and detailed documentation.

**CONTACT US FOR A QUOTE ON ANY  
GREENHOUSE SIZE YOU DESIRE!!**

800-634-6362

# Top Spray Automatic Growing System for Vertical Bag Culture

The vertical bag culture growing system developed by **Hydro-Gardens** is adaptable to any size greenhouse. Many different combinations of timers, injectors or nutrient holding tanks can be used. The basic system includes 5 gallon black growing bags with a sprayer in each bag. The sprayer has 24" spaghetti tube which connects to a 3/4" or 1" poly pipe nutrient line running the length of the greenhouse. The spaghetti line is inserted into the poly line with a simple punching tool. No glue or grommets are required.

A 24 volt automatic valve in the center of each zone (single or multiple rows) is attached to an underground PVC header pipe which runs across the width of the greenhouse. A PVC tee is placed in the header line for each automatic valve and is connected to the poly line with a poly combination tee. Since the valve is normally closed until energized by the control device, the header line is always under pressure (30-50 psi). Each zone is fed individually as programmed and activated by the Solar Irrigation Controller, sequence timer, or computer.

The nutrient supply system (injector, pump, etc.) is designed according to the size of the greenhouse and type of crop to be grown. For example, a typical 5 row greenhouse only needs the Solar Controller. A 24 zone greenhouse may also need a 24 station timer. Using a sequence timer to feed one row at a time may be less expensive than increasing the injector size to water multiple rows. If a large nutrient holding tank is used with a pump sufficient to feed all rows at one time, then a sequence timer is not required. However, it is apparent that an injector and solar controller system is far more practical, less expensive, and requires less space than installing large nutrient tanks.

The selection of the injector system and control device(s) is an important part of the overall design. Certain factors must be known: 1) the number of zones, 2) the number of feeders per zone, 3) the water volume available to the greenhouse, and 4) the water quality. **Hydro-Gardens** offers designs for any size greenhouse and any major type of crop. Solid state timers are available in an assortment of numbers of stations. The timer can be activated by the solar controller which measures available sunlight. You adjust the solar controller to water the plants only when they are receiving adequate sunlight. Solar controller models with 3 and 12 stations are available.

**Hydro-Gardens** offers three types of injectors. The Anderson and Dosmatic Injectors are driven and controlled by water volume. The less expensive Chem-Feed injectors are driven by an electric motor. All provide the function of changing our Chem-Gro fertilizers from the concentrated form into a plant usable fertilizer by metering out the correct amount of concentrate into the water supply line.

**Anderson** and **Dosmatic** injectors are designed to handle variable flow rates of water. There are sizes with maximum water flow rates of 20, 30, 50 and higher gallons per minute (GPM). They operate accurately anywhere from 1 GPM to their maximum. The dial on each pump head of the Anderson water driven injector is easily adjustable to deliver the desired quantity of concentrated fertilizer to the fresh water supply line going to your plants. The pumping action of the pump heads is controlled by the water motor. Each Dosmatic is individually adjustable with dosage rings, and uses a piston to deliver concentrate. The value of both injectors is the fact that each delivers the correct volume of fertilizer concentrate over a wide range of fluctuating water pressures and volumes. These injectors are very accurate, dependable, and completely automated. More specifications can be found in the pages of this catalog.

The **Chem-Feed** injector is an electric motor driven pump that delivers a constant flow of fertilizer concentrate to the fresh water supply going to your plants based on the dial setting on the face of the pump. It's accuracy is totally dependent on the volume of fresh water delivered to the plants. If your fresh water system cannot deliver a constant volume of water, you will not be able to accurately adjust the pump to deliver the correct amount of fertilizer concentrate. The Dole 10 GPM regulator adjusts flow rates that are greater than 10 GPM, down to 10 GPM. The maximum number of sprayers per zone is about 140. Thus the **Chem-Feed** system is dependent upon having a constant PSI and water flow. For this type of injector system all individual rows (zones) of plants **must** have the same number of sprayers. This will guarantee equivalent dilute solutions to each row (zone).

It should be apparent that a properly engineered design can have long term labor and operating cost savings and can enhance your crop production. **Hydro-Gardens** has the experience required to provide the system for your operation.

**VERTICAL BAG LAYOUT**

**SEE PAGE 102**

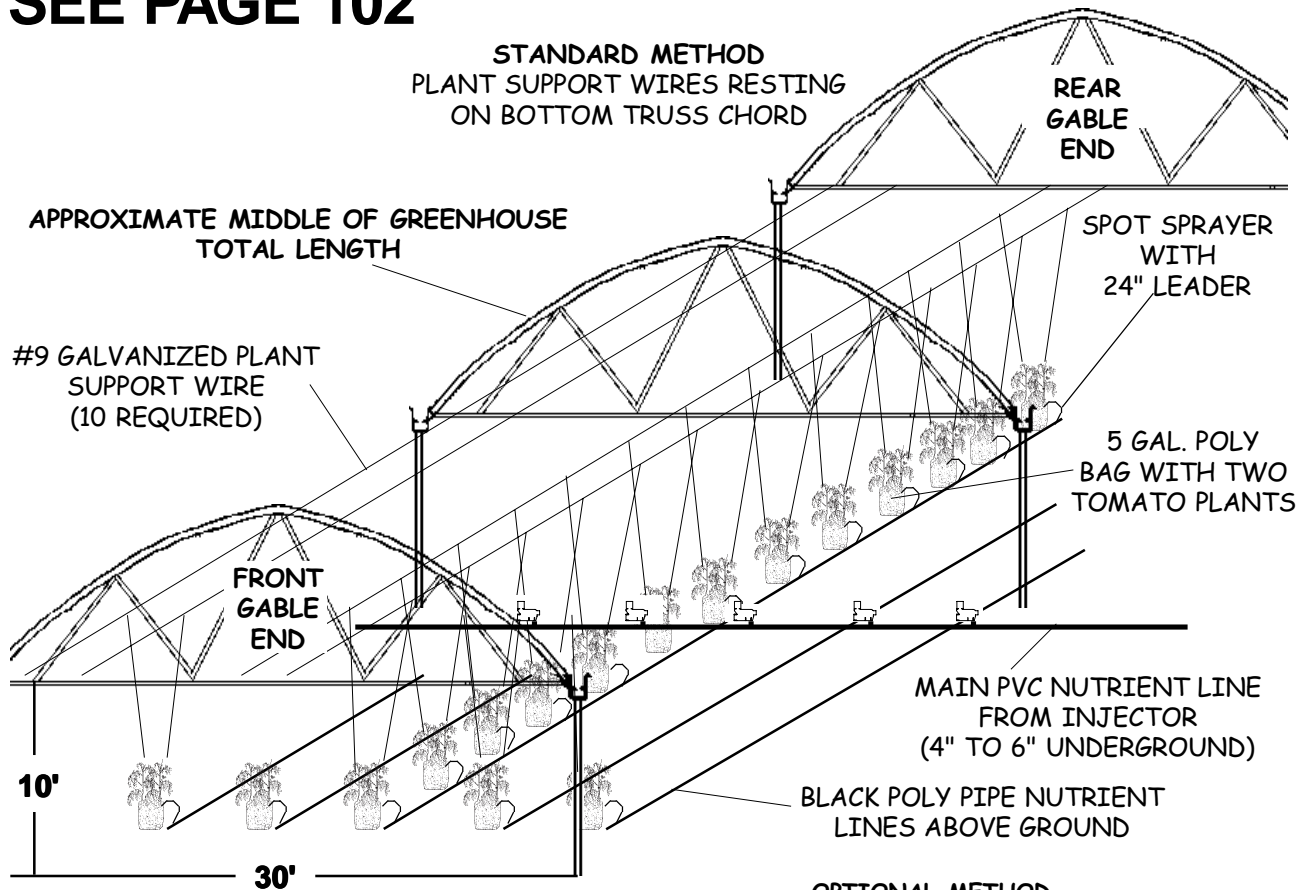

**FIVE SOLENOID VALVES PER GREENHOUSE BAY**

- 5 valves (stations) per bay :  
(One spray stake for each 5 gallon bag)
- Injector Options are:  
Chem-Feed (less than 10 GPM per station)
- Maximum of 140 spot sprayers (6W240)
- Dosmatic (less than 30 GPM per station)  
Maximum of 420 spot sprayers
- Anderson (less than 30 GPM per station)  
Maximum of 420 spot sprayers

- 1 valve (station) per bay:  
Injector options are:  
Anderson 4 head injector  
Maximum of 650 spot sprayers
- Anderson 4 head high capacity  
Maximum of 1200 spot sprayers

Twice as many Spot Drippers (6W248) can be used as Spot Sprayers (6W240). It is assumed that a minimum of 25 PSI can be supplied to the growing system.

**OPTIONAL METHOD**  
SUSPEND PLANT SUPPORT WIRES BELOW BOTTOM TRUSS CHORD WITH ANOTHER SUPPORT WIRE.

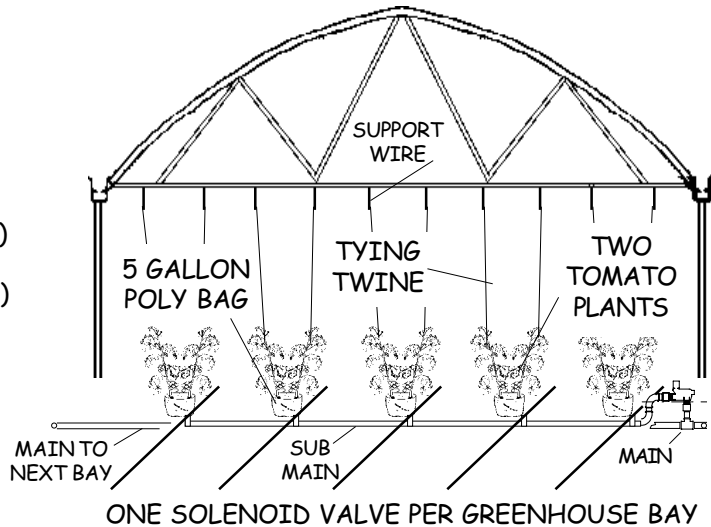

<b>GROWING SYSTEM SAMPLE PRICING</b>	
5 @ 30' x 132' w/Dosmatic (19,800 sq.ft.):	\$ 4,205.00
12 @ 30' x 276' w/Anderson (99,360 sq.ft.):	\$ 14,509.00