

INSTALLATION AND OPERATION INSTRUCTIONS
FOR AMERICAN COOLAIR'S
ALUMINUM EVAP-PAD COOLING SYSTEM

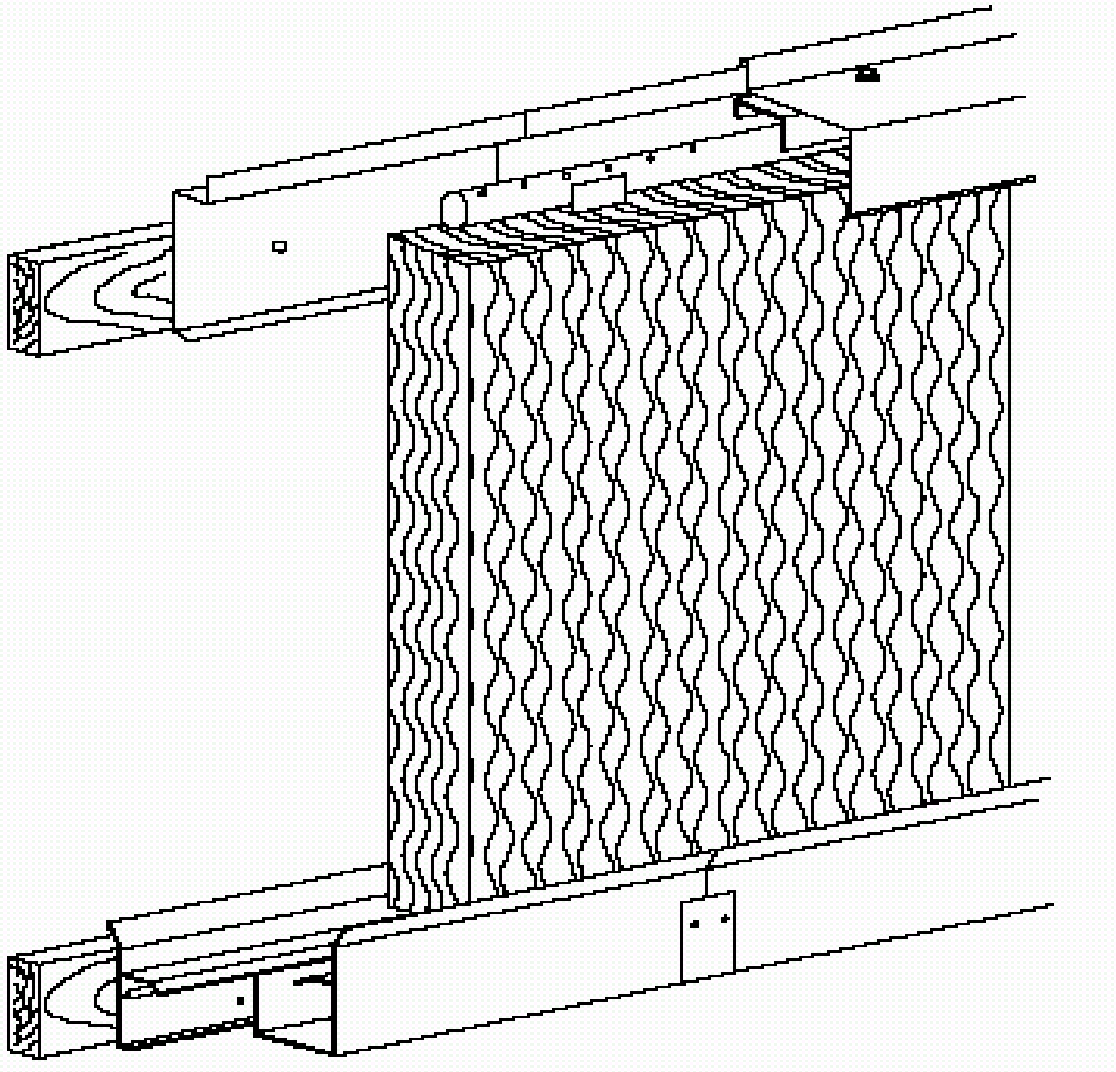

Distributed By:



Hydro-Gardens
P.O. Box 25845
Colorado Springs, CO
80936-5845
888-693-0578
hgi@hydro-gardens.com
www.hydro-gardens.com



TABLE OF CONTENTS

	PAGE
I. CONCEPT OF EVAPORATIVE COOLING	2
II. RECOMMENDED TOOLS	3
III. PARTS LIST	3
IV. PAD LOCATION IN BUILDING	4
V. INSTALLATION PROCEDURES	4
VI. START UP PROCEDURE	14
VII. OPERATION INSTRUCTIONS	17

I. CONCEPT OF EVAPORATIVE COOLING

To offset periods of extreme temperature that affect the in-house environments, and therefore production, Coolair evaporative cooling systems are used with outstanding success. The benefits of evaporative pad cooling are obtained by moving large quantities of air through water-saturated pads. The resulting evaporation of water will lower the air temperature 10 to 25 degrees. This method of cooling can provide dependable relief from heat stresses in periods of hot weather. Suited for all geographic locations, a Coolair Evap-Pad System delivers the greatest economic benefits in areas where higher temperatures during longer periods of time are normal.

II. RECOMMENDED TOOLS

The following is a list of tools required for the installation of your Coolair Evap-Pad System.

Tape Measure	Hack Saw
Chalk Line	Caulk Gun
Level	Screwdriver
Drill with 5/32" Drill Bit	Tin Snips
3/8" and 5/16" Sockets and Drive	

III. PARTS LIST

A. Your Coolair Evap-Pad System consists of:

1. A water distribution and return system complete with the correct number of the following parts:
(Number of some parts is dependent upon size of system)

1 1/2" PVC Distribution Pipe	Pipe Cover Back Plates
PVC Female Adapter	Pipe Covers
PVC End Plugs	Pipe Supports
1 1/2" PVC Distribution Pipe Tee	Pipe Cover End Caps
PVC Pipe Cement	Various Fasteners
Troughs	Drip Pans (for 4" pad systems only)
Trough Hangers	Pad Spacers (for 4" pad systems only)
Trough Connectors	
Trough End Caps	
Pad Retainers (for all 7' and 8' systems and 4" thick 5' and 6' systems only)	

2. A Plumbing Kit
3. Evaporative Cooling Pads
4. Sump Pump

B. Parts required for the Evap-Pad System, but that are not supplied by Coolair consist of:

1. Framing Materials
2. Sump Tank, Sump Drain and Sump Cover
3. Return Pipe from Trough Drain to Sump
4. Water Supply to Float Valve

IV. PAD LOCATION IN BUILDING

For greenhouse applications, the pads' midpoint should be centered on the crops to be cooled. The pads should be located on one end of the building and the fans on the other end, except in wide greenhouses where the pads should be on one side and the fans on the opposite side.

For poultry or livestock applications, the top of the pads should be at the highest level at which cooling is desired. The pads should be located on one end or side of the building, with the fans on the opposite end or side. The air should be drawn the length of the building except in cases where the resulting air velocity exceeds the comfort level for the animals being housed. In these cases, the pads should be on both sides at both ends of the house, with the fans on both sides in the middle.

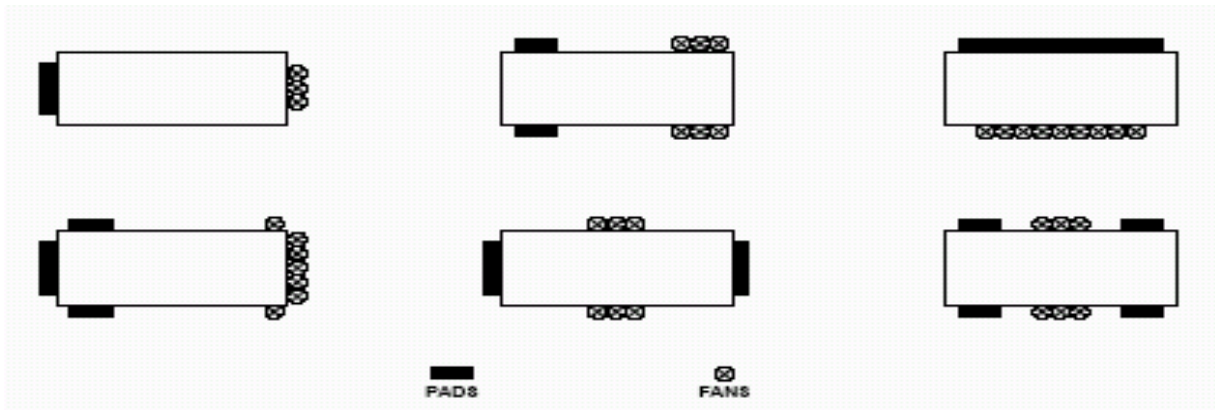

Many other designs are acceptable. Contact your Coolair representative for recommendations.

V. INSTALLATION PROCEDURES

The desired opening should be the ordered pad length by the ordered pad height minus 2". For example, if you ordered a 45' system which is 5' tall, then your opening would be 45' x 58". See Figure 1. This opening should be framed by 2 x 6 stringers minimum, made of water-resistant wood. When fastened to a metal building or greenhouse, the opening should be framed with angle or Z support of sufficient strength to support a maximum of 20 pounds per linear foot of pad with 4" pad or 30 pounds per linear foot of pad for 6" pad systems. There should be a minimum of 6" clearance from the top of the pipe cover to any obstruction that would hinder the removal of the pipe cover to perform routine maintenance such as clogged holes in the pipe.

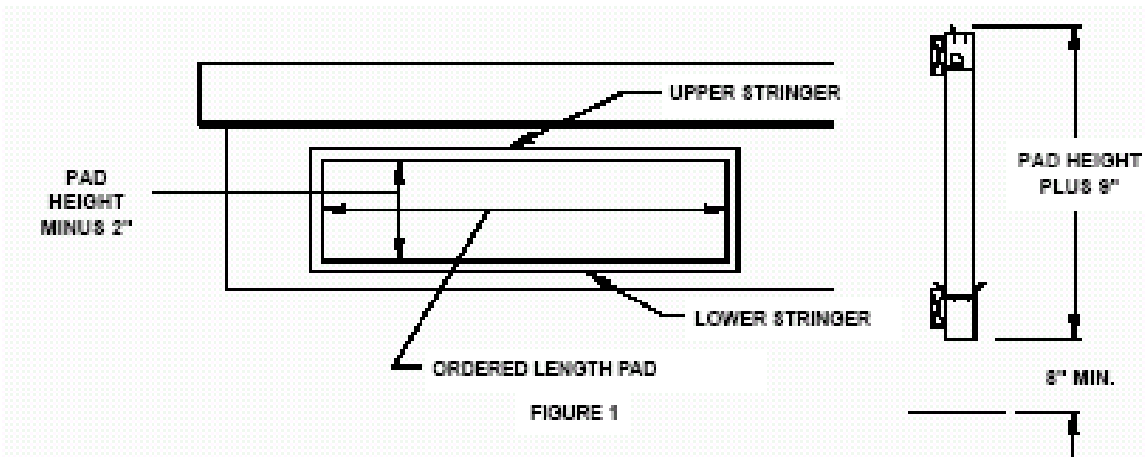
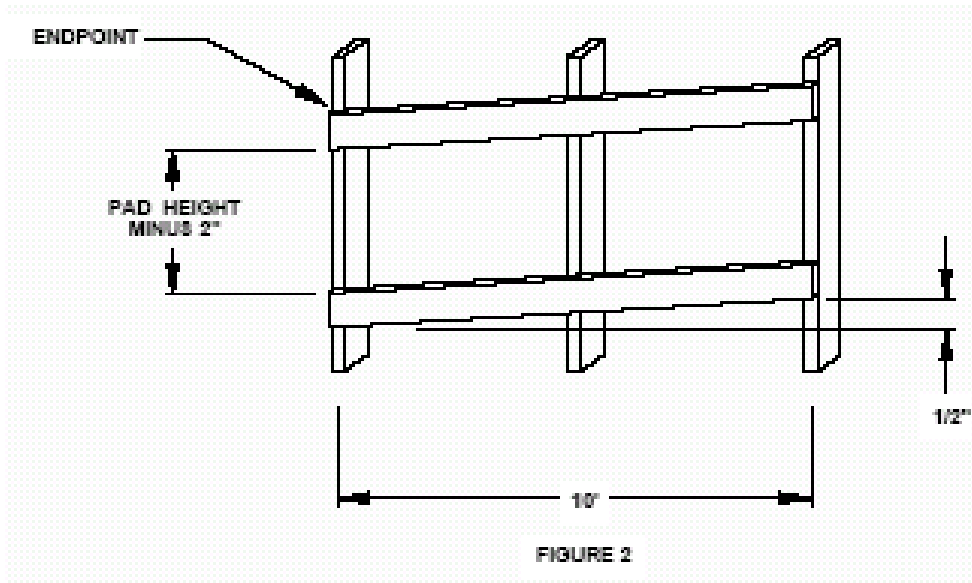

FIGURE 1

A. Installation of Upper and Lower Stringers - 5 to 25 Foot Systems



B. Installation of Upper and Lower Stringers - 30 to 110 Foot Systems

First locate the midpoint of your Evap-Pad System. This is the ordered pad length divided by 2. Locate the Evap-Pad System vertically as determined by the specific use of the system (see Section IV). The bottom of the lower stringer should be placed a minimum of 8" above any obstructions in the center of the pad system. This space needs to be available to be used for piping to the sump. Using a level and chalk line, determine a level line on each side of the midpoint to the ends. At each end of the system, raise the end of the chalk line 1/2" for every 10 feet of system length from the midpoint. (Example: An Evap-Pad System with a total length of 40 feet would drop 1" from the end of the midpoint). Use the chalk line to mark each stud and then install the lower stringer. The upper stringer should parallel the lower stringer. The spacing between the upper and lower stringers should be pad height minus 2". See Figure 3.

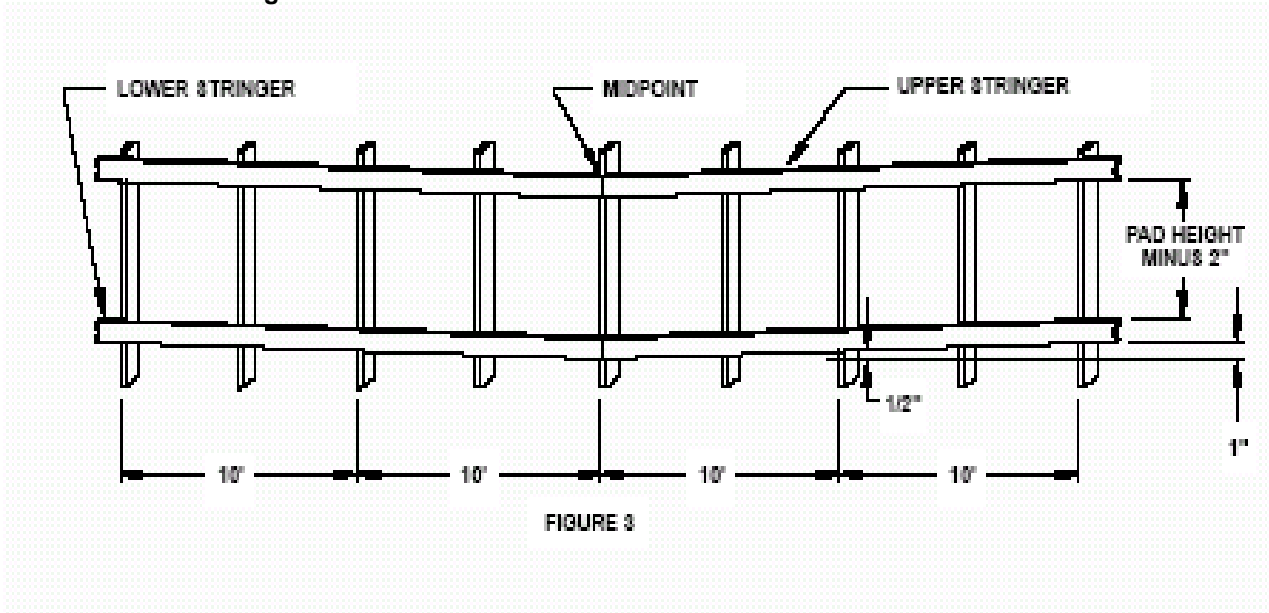

C. Installation of the Middle Stringer

When 5, 6, 7 or 8 foot pads are used, it is necessary to install a 1 x 4 middle stringer. This stringer should parallel the other stringers. For 5 or 6 foot pads, the middle stringer should be halfway between the upper and lower stringers. For 7 or 8 foot high pad systems, position the middle stringer 51" from the top of the lower stringer to the top of the middle stringer. See Figure 4.

PAD THICKNESS	PAD HEIGHT			
	5'	6'	7'	8'
4"	33"	39"	51"	51"
6"	N/A	N/A	51"	51"

NOTE: For 6" pads, tall pad supports are not required on the 6' or 8' pads.

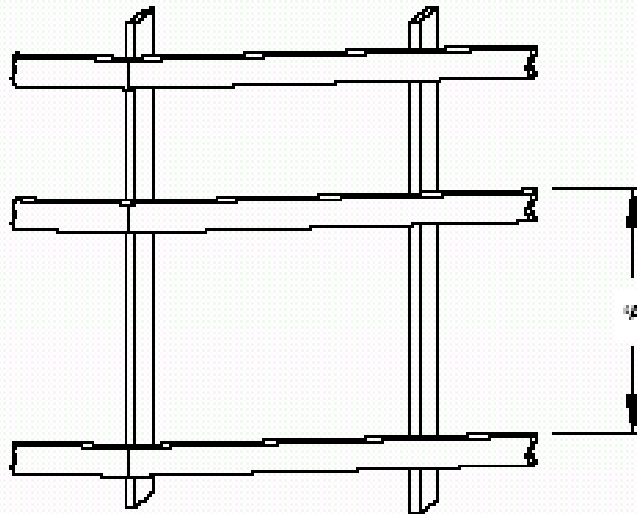

FIGURE 4

D. Installation of the Trough Hanger

The trough hanger is to be mounted with its anglebreak flush with the top edge of the lower stringer. Secure it to the stringer using the 1/4" x 1-1/2" lag bolts. See Figure 5. If the system is 5 to 25 feet long, install the appropriate section of the trough hanger starting with the end of the system. If the system is 30 to 110 feet long, install a 5 or 10 foot section of the trough hanger starting with the end of the trough hanger at the midpoint of the system. Install the trough hanger so that the joints in the trough hanger and the trough are staggered and do not fall at the same spot. Next proceed to mount the rest of the trough hanger sections to the lower stringer, butting them against the previously installed piece.

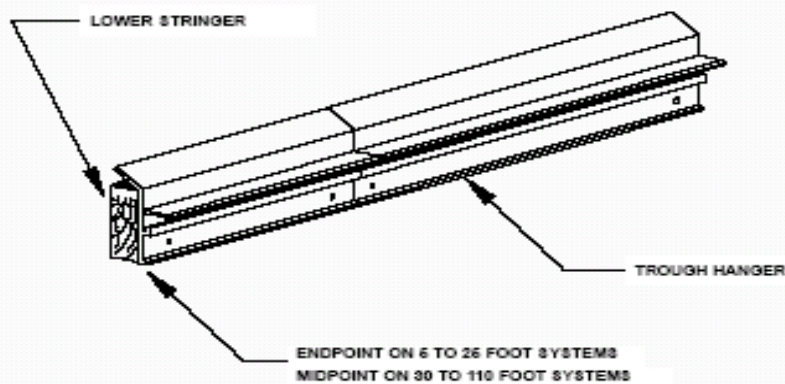
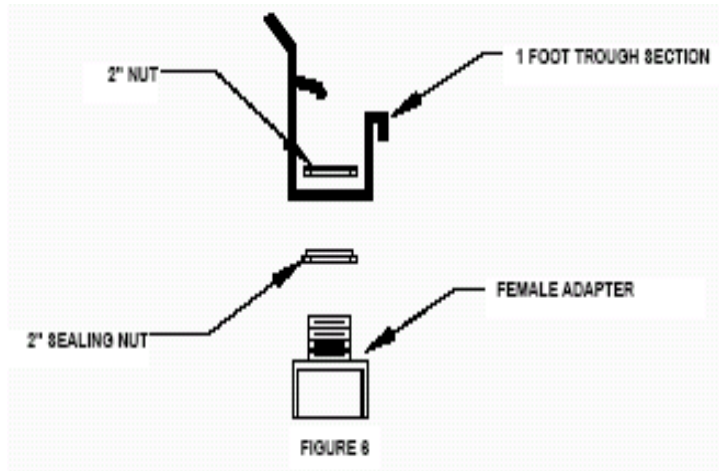

FIGURE 5

E. Assembly of the Downspout and End Cap Sections

Locate the 1 foot long trough section (with downspout hole). The downspout is to be assembled to this trough section. Find the 2" PVC female adapter and the two 2" steel nuts. Thread the 2" sealing nut approximately onehalf inch onto the threaded part of the female adapter. Place the 1 foot long trough section on top of the installed nut. Next thread the second nut onto the female adapter. See Figure 6. Additional caulking around the joint is recommended.



On 5 to 25 foot systems, the downspout and the sump can be located at one end of the system.

On 30 to 110 foot systems, the downspout and the sump should be located at the center of the system.

Install the end caps in either the one foot downspout section for one end of the short systems or in the trough ends of systems with downspout in the middle. Using a drill with a 5/16" socket and #10-16 x 3/4 self-drilling screws, install 3 screws to hold end caps in the trough. Place one screw centered in the bottom of the trough 3/8" from the edge. The front and back screws should be 2" from the bottom, 3/8" from the edge. See Figure 7. Caulk the end caps thoroughly

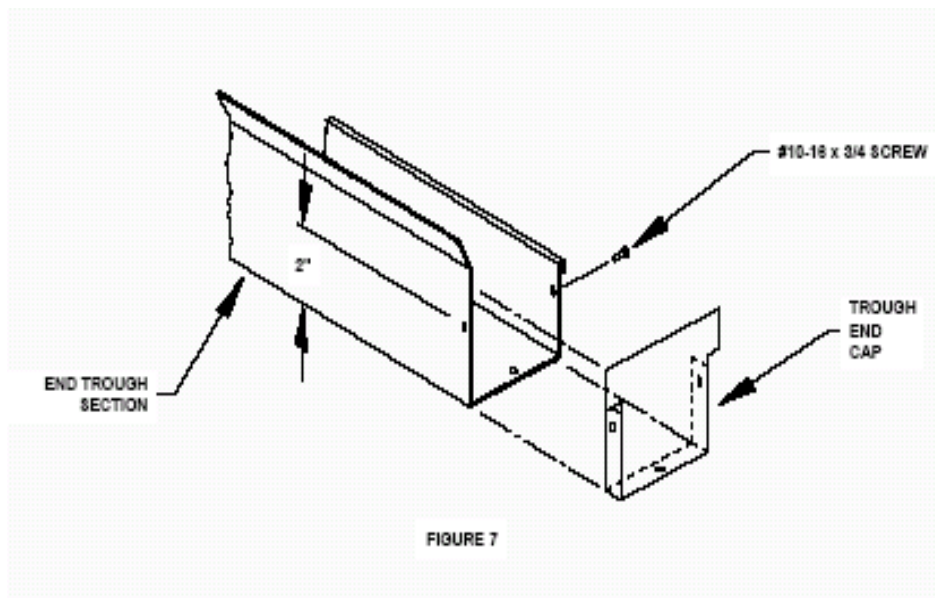

F. Installation of the Trough

Hang a piece of trough on the trough hanger next to the downspout section. The joints in the trough hanger should be offset from the joints in the trough. Find the trough connectors, they are U-shaped aluminum strips. Caulk the trough joint thoroughly. Place the trough connector over the trough joint with the long side of the connector on the outside of the trough. Using #10-16 x 3/4" self-drilling screws, place two screws 3" from the bottom of the trough, one in each piece of trough. Also drill two screws in the trough bottom, one in each piece, 1" from the back of the trough. Repeat for each trough joint.

1 foot must be cut off of one of the 5' or 10' sections of trough to make room for the 1 foot long trough section (with downspout hole).

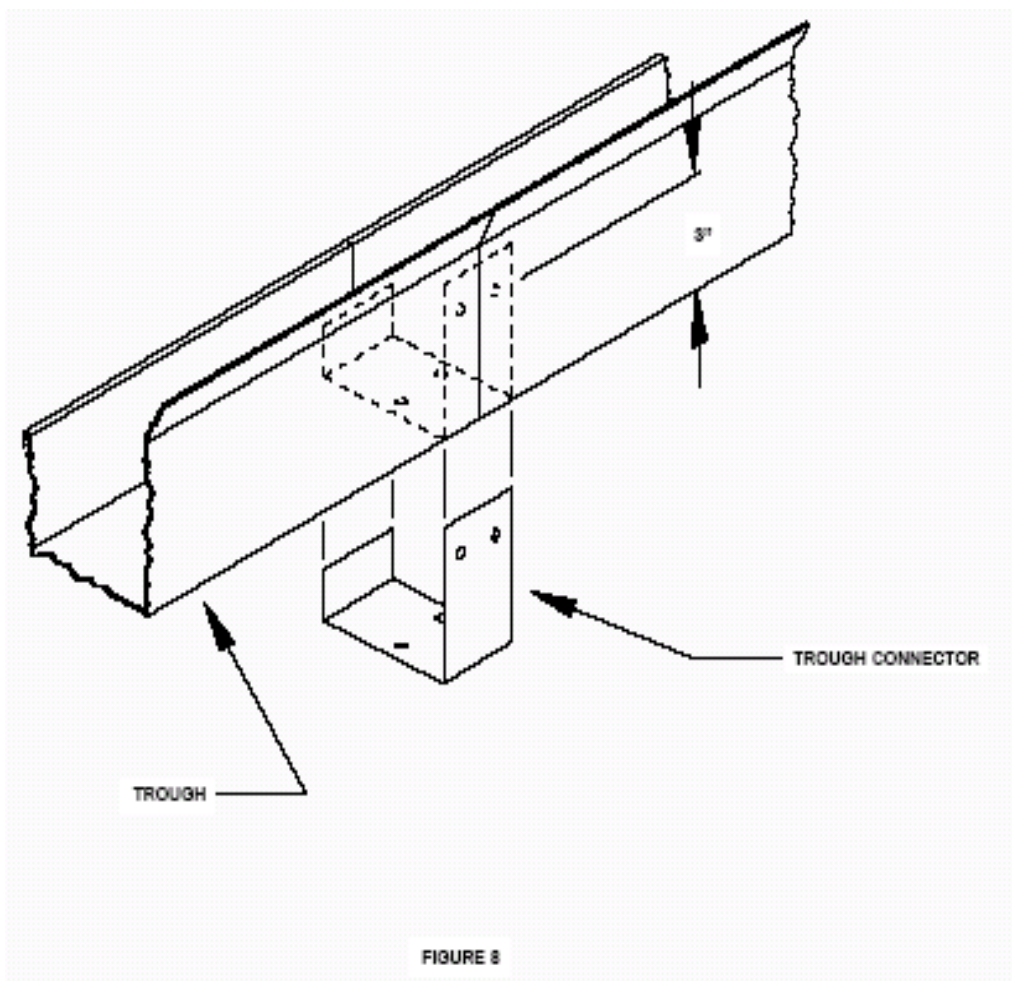

G. Installation of the Pipe Cover Back Plate and Pipe Support

For ease of installation, mark a point 1-1/2" up from the bottom of the upper stringer. Do this at the midpoint and at both ends of the system. Next mark a chalk line through the three points. This indicates the location of the pipe cover back plate mounting holes. Sight through the prepunched mounting holes in the back plate and line up the chalk line through them. This puts the support at the correct mounting height. Secure in place using the rubber grommets lag bolts. See Figure 9.

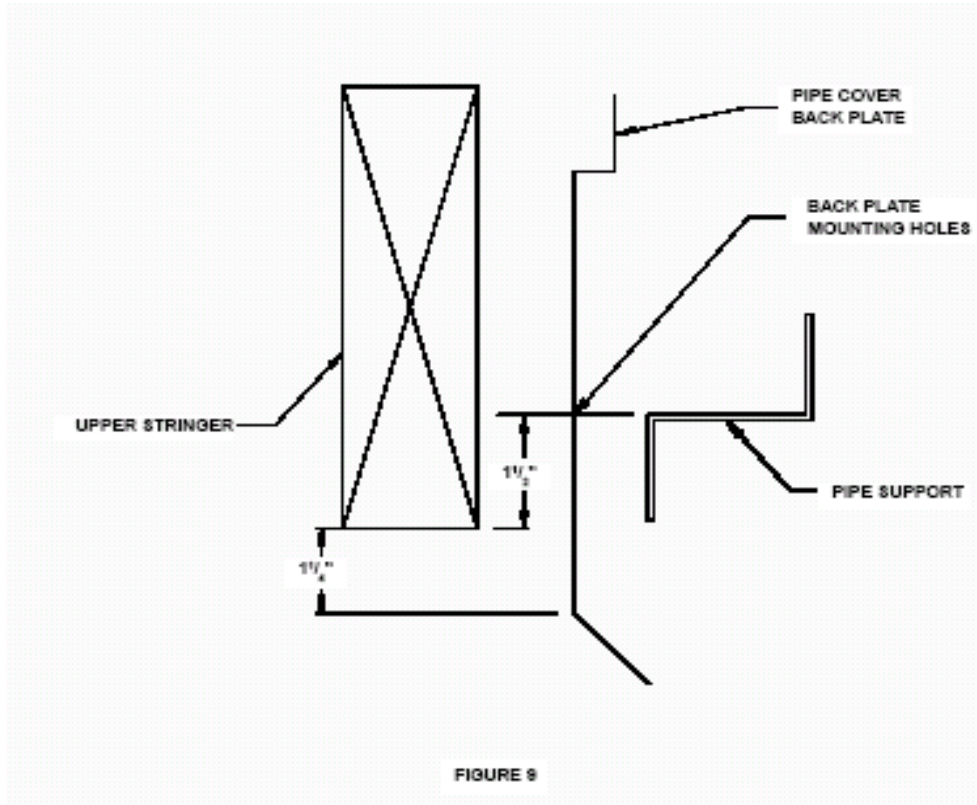

Install the pipe support on the pipe cover back plate using the holes provided, one support per 5' back plate. See Figure 9.

Install the pipe cover back plates and pipe supports for the entire length of the system. Caulk the joints between all back plates to help prevent water leaking to the stringer.

H. Installation of the Distribution Pipe

To install the distribution pipe, place a 10 foot section on top of the pipe support with the metered holes pointing at approximately the 1 o'clock position (for installation on the outside of the building) or the 11:30 o'clock position (for installation on the inside of the building). See Figures 10A and 10B. This position is necessary to provide proper water distribution. The 1-1/2" PVC Tee should be placed directly above the pump. The connections do not need to be cemented, but should be pushed together tightly. Continue joining pipe sections together using couplings.

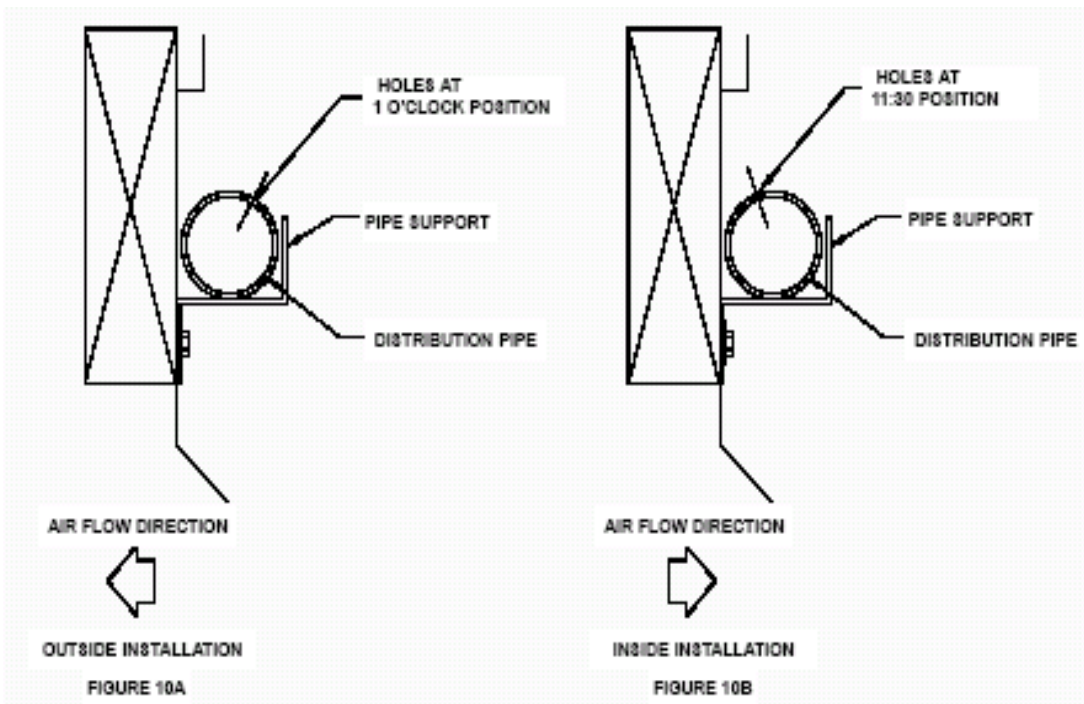

After the distribution pipe has been installed over the length of the system, use the PVC cement to attach a PVC female adapter to each end of the pipe. If the pump is on the end of a short system, use a short piece of 1-1/2" pipe on the other side of the tee and cement the female adapter to the end of the pipe. See Figure 11. After both female adapters have been cemented, screw the end plugs into the female adapters. For systems with the pump in the middle, add pipe to the tee in the opposite direction as listed above.

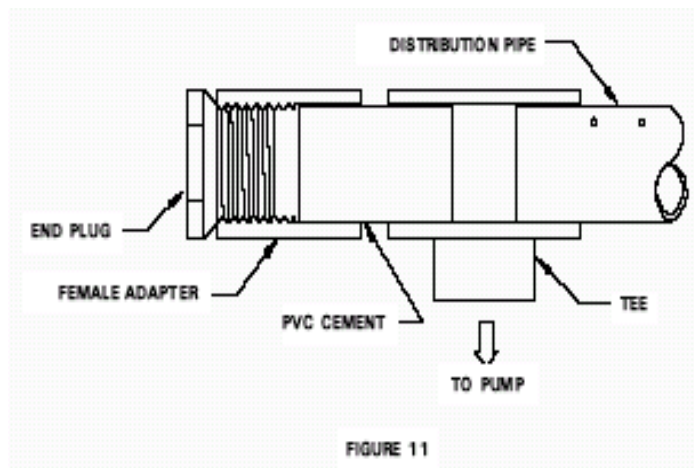

I. Pad Installation for 4" Cooling Pads

For American Coolair's aluminum evaporative cooling systems that use 4" cooling pads, two additional types of parts (pad spacers and drip pans), are included with each system. See Figures 12 and 13. Both parts are aluminum and 5' in length. These parts are used to properly secure the 4" cooling pads in the system's trough.

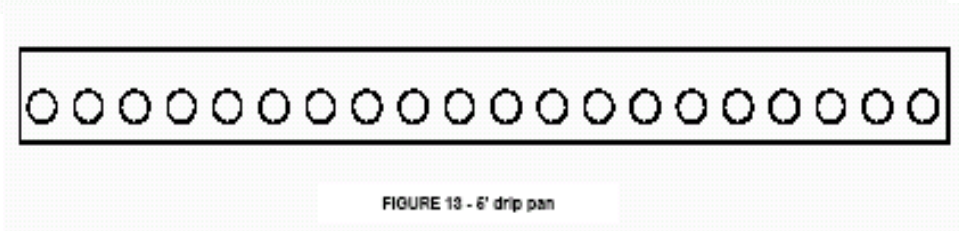
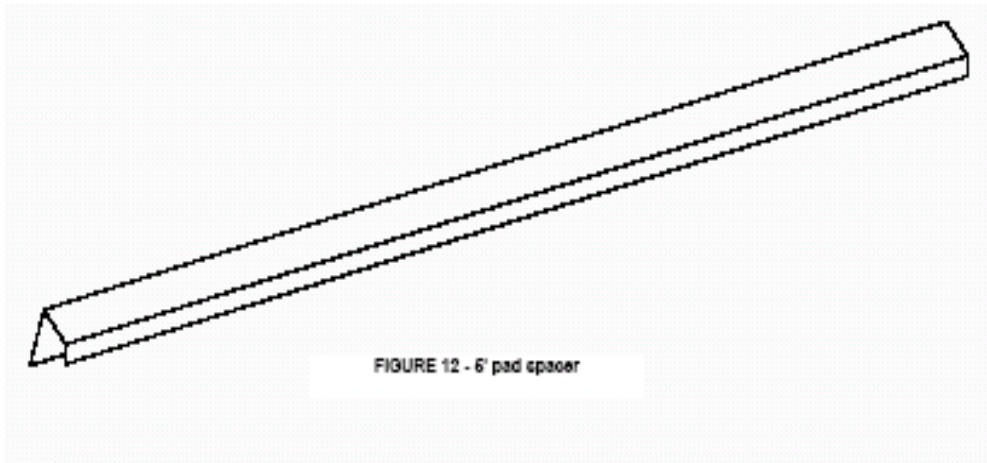

After the trough and distribution pipe have been installed, but before the pads are installed, place the 5' drip pan sections the length of the trough. The drip pan should be installed with the holes closer to the stringer side of the trough. The drip pan will act as a seat for the pads. Next, place each pad on the drip pan, sliding it to the rear of the pan. Then, insert the pad spacers in front of the pad to ensure a secure fit. See Figure 14.

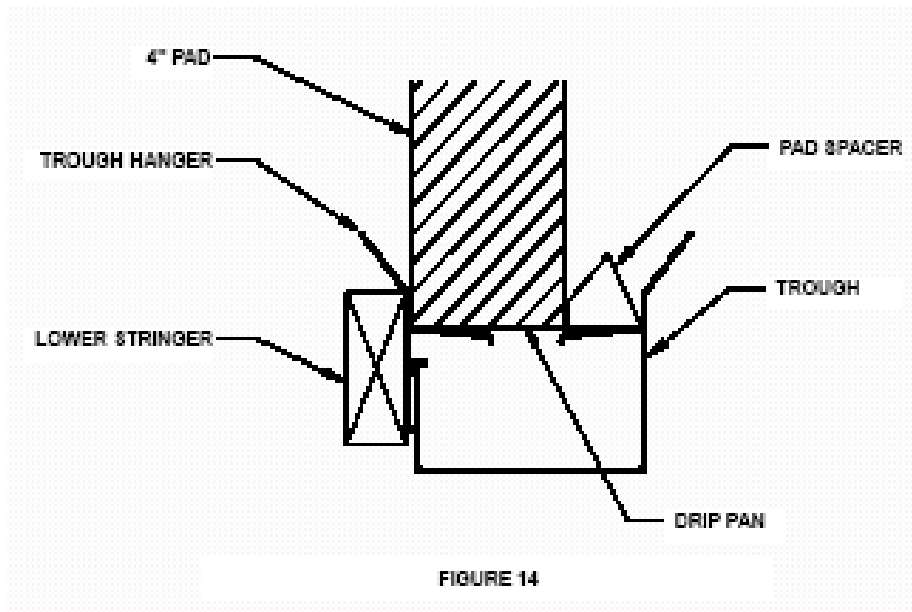

J. Pad Installation

The evaporative cooling pads can now be placed onto the assembled trough.

If the system is 5 or 6 feet tall and 4" thick, then a pad retainer is used to prevent the pads from bowing. Place a pad into position on the trough. Set the U-shaped end of the pad retainer over the middle stringer. Next, slide it onto the pad. Now install the next pad and install another pad retainer. Continue until the system is complete.

If the system is 7 or 8 feet tall, then a pad retainer is used at each intersection of four pads to prevent them from separating. Place a bottom pad (4 ft. tall) into position on the trough. Next, set the top pad on top of the bottom pad. Slip a pad retainer onto the middle stringer and slide it over the joint of the two pads. Now install two more pads, sliding them into the rings of the already installed pad retainer. Repeat this procedure for the entire length of the system. See Figure 15.

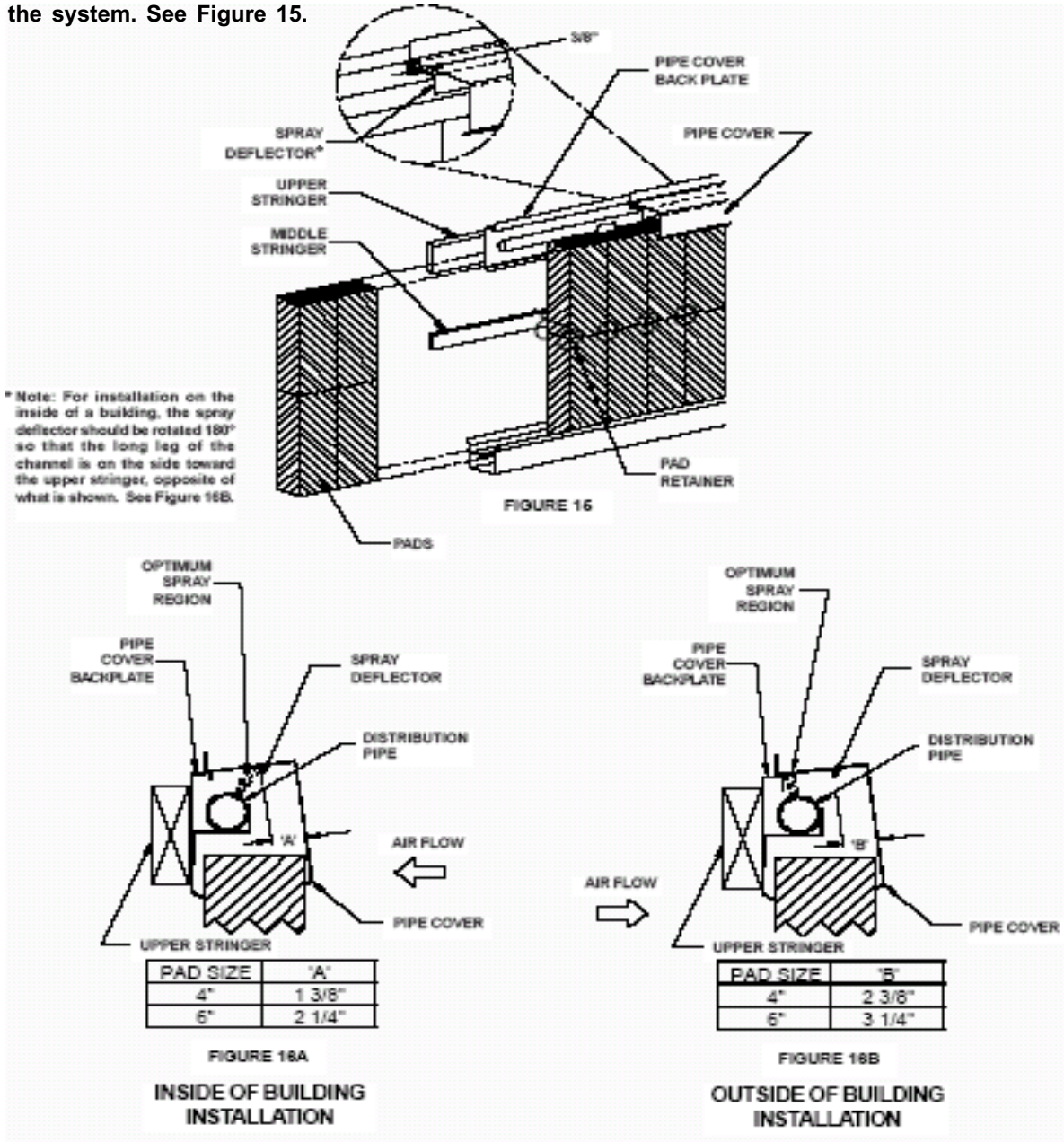

K. Pipe Cover Installations

In the pipe distribution parts kit, you will find channel shaped 5' pieces of aluminum. These are the full length spray deflectors to be fastened onto the pipe covers. Fasten these spray deflectors on the pipe cover with the self-drilling screws provided (see Figure 16A or 16B for diagram and dimensions). The spray deflectors lap the joint of the pipe cover 3/8" to prevent leakage at the joint as well as direct the water onto the center of the pad (Figure 15 shows this configuration). The pipe covers are installed by slipping them onto the top flange of the back plate. With a pair of vise grips, crimp the doubled flange on the pipe cover in at least three places to obtain the desired tension when placed over the back plate flange. It will be necessary to cut a slot out of the pipe cover at the water supply tee. Care should be taken not to cut a slot any larger than necessary at the tee to prevent the spillage of water from the system. See Figure 17.

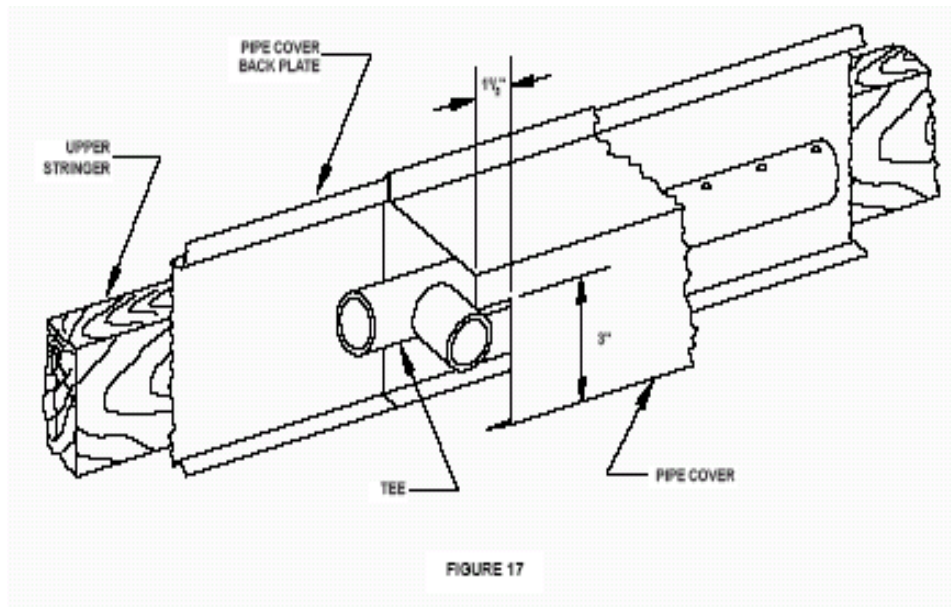

Next the pipe cover end caps are to be installed. Holes must be cut in the end caps in order for them to sit flush with the end of the pipe cover. Place the end cap on the upper stringer at the end of the distribution pipe. Mark on the end cap where this pipe is to go through. Using tin snips, cut a hole in each end cap and mount them to the upper stringer using rubber grommets lag bolts. See Figure 18.

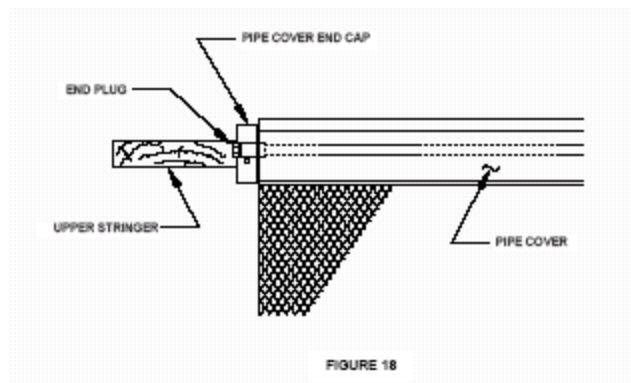

L. Installing the Sump, Pump and Piping

Sump:

Locate the sump directly under the tee, the distribution pipe and the water return downspout. The sump should have a drain plug so it can be cleaned periodically. The sump capacity should be 3/4 gallon for each square foot of pad area. Place the volume control valve and the filter a minimum of 3 feet above the discharge side of the pump. On the intake side of centrifugal pumps, a minimum of 2 feet of straight pipe is necessary for proper operation. The low water operating level should be at least 2" above the pump suction inlet. The sump should be provided with a cover to keep out windblown dirt and debris. A medium mesh screen should be placed over the return water outlet. Clean periodically when needed. See Figure 19 (Submersible Pump Systems) or Figure 20 (Centrifugal Pump Systems).

Pump:

Operation and maintenance instructions are packed with each pump. For Evap-Pad Systems longer than 110 feet for 4" systems and 90 feet for 6" systems, use two pumps and water distribution systems.

Piping:

Use the pipe sizes recommended in Figures 19 & 20 for an adequate supply of water for the system. Glue all PVC fittings from the pump to the tee in the water distribution system.

VI. START UP PROCEDURE

Remove the end plugs in the distribution pipe. Prime the pump per the instructions included with the pump. Next, fully open the volume control valve. Turn the pump on and let it run for a few minutes to flush out any debris that has accumulated in the system. Turn the pump off and replace the end plugs. Turn the pump on and remove the last pipe cover. The water should be squirting up 3-4 inches. Adjust the volume control valve until the proper flow is achieved. Check the complete length of the distribution pipe to be sure that none of the holes are plugged. Use a piece of wire to unplug any holes that need it.

To ensure that you are getting the best performance from your system, check to be sure that the entire pad is getting wet. Also, make sure that the pads fit tightly, not allowing any air to leak around them.

When first starting the system, it sometimes takes several hours of operation for the pads to become completely wet. After the initial wetting, the pads should wet in a few minutes. Complete pad wetting may also be a problem due to dust accumulating after the pads have been dry for several months.

The initial wetting can be aided by spraying water on the pad with a garden hose and also flooding the pads with excess water for the first hour. After the pads become wet the first time, turn the water down by use of the volume control valve until the water comes down the pad in a soaking action and not a stream flooding down the pad.

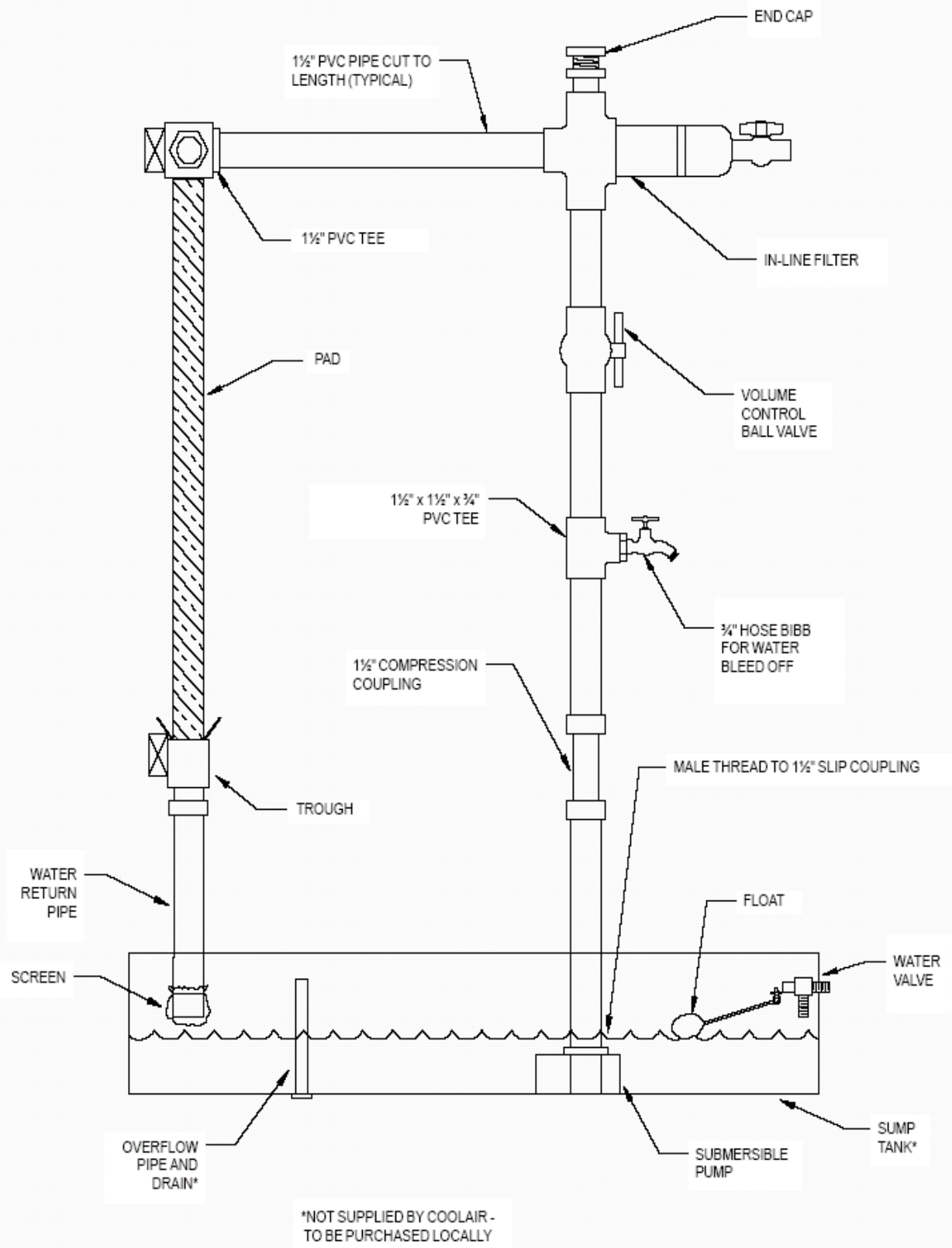

FIGURE 19 - SUBMERSIBLE PUMP SYSTEM PLUMBING HOOK-UP FOR P-20, P-25 and P-40S PUMPS

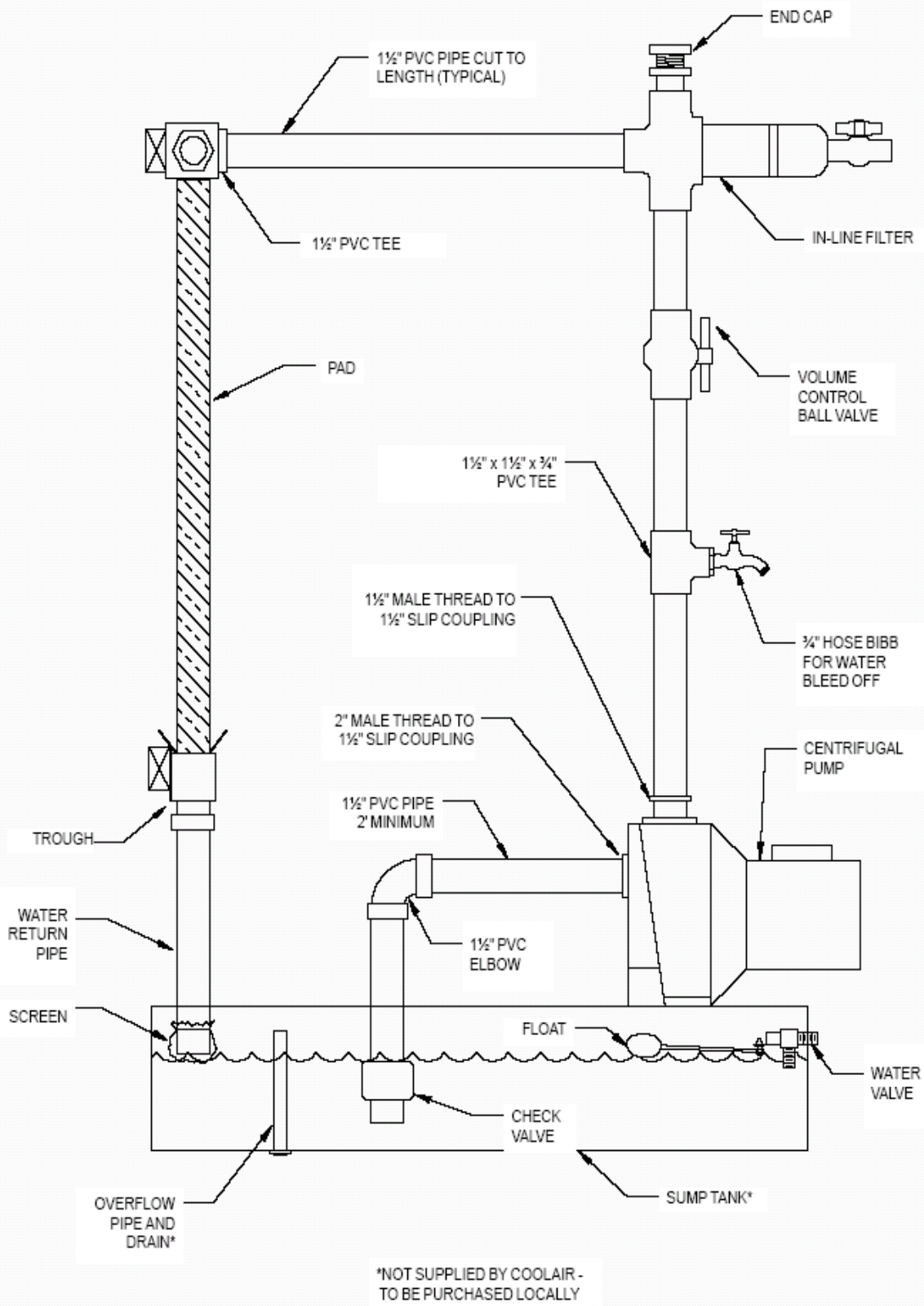

FIGURE 20 - CENTRIFUGAL PUMP SYSTEM PLUMBING HOOK-UP FOR P-40 and P-50 PUMPS

VII. OPERATING INSTRUCTIONS

- 1 The pads are very durable and will last 5 or 6 years if properly maintained. When the water is circulated and evaporated, the mineral content of the remaining water gets higher. To keep the mineral content within workable levels, 5% to 10% of the circulated water must be bled off through the hose bibb. When mineral deposits are observed on the pad, increase the amount of bleed off.
- 2 The pH of the recirculated water must be maintained between 6 and 9. A pH of 7 is neutral water. A pH above 9 or below 6 will drastically reduce the life of the pad.
- 3 Algae growth and water bacteria in the pads must be controlled. The pads are treated with a fungus resistant additive but this does not completely prevent algae growth. Treat the water with any of the chlorine algaecides (Calcium Hypochlorinates) used for swimming pools, HTH or Pace. Tablet forms of these algaecides are the most economical and best to use in the sump for slow release. Maintain the sump water for recirculation at 1 ppm (part per million) chlorine. If a chlorine smell is present, too much has been added. If any algae grows, tablets need to be added. Water pH and chlorine levels should be checked weekly. Kits for testing pH and chlorine may be purchased at any swimming pool supply store. The life of your pad depends on its proper maintenance. Do not use copper sulfate in the system as it will corrode the pump and other metal parts of the system.
- 4 Clean the filter at least once a week, more often if foreign materials are present in the water system.
- 5 Flush pipe distribution system at least once a month. This is done by opening both ball valves while the pump is running and allowing water to flow through and out of the system.
- 6 Regulate your ventilation system so that the pad system is turned off while all the fans are still running. This will pull air through the pads after the water is turned off, allowing them to dry properly and killing the algae spores. Do not keep the pads wet around the clock as this will also make the pads soft.
- 7 When the evaporative pad system is operating, check the pads for dry spots. When dry spots are observed, remove the pipe cover and check the holes in the pipe. Clean any stopped up holes with a wire until adequate water flows from each hole.
- 8 **DO NOT FLOW EXCESSIVE WATER ON THE PAD.** The pads are more efficient if they just have enough water to keep them wet, but not a stream of water cascading down the pad.
- 9 Drain and clean the sump as necessary to remove any dirt or trash that it may have accumulated.
- 10 At the end of the evaporative cooling season, drain the pump, sump and pipe system to avoid freezing damage in cold weather. If the pump cannot be completely drained, put anti-freeze in it.